

E-Guard



Mercedes-Benz



Mercedes-Benz Guard

The finest World of Protection. E-Guard



Contents

- 6 Philosophy
- 12 Development
- 14 Testing
 - 18 Ballistics & explosion testing
 - 24 Protection concept
 - 28 Comfort & technology
 - 52 Equipment & appointments
 - 58 Facts and figures
 - 60 Service and warranty

Personal protection

The right answer: E-Guard. Those who have to travel a lot need to feel safe, especially in a world of ever-increasing security threats. Here it is important that a special-protection vehicle should not be recognisable as such, but maintain a low-key profile instead: discretion is of the essence. The only conspicuous feature: the E-Guard possesses and affords all the advantages of the E-Class, the world's most successful business-class saloon – athletic elegance, attentive comfort and convincing workaday practicality. An example for all.







Invitingly distant

Safety and comfort go hand in hand in the E-Class. It can identify speed-limit signs on the road as well as detect and indicate vehicles in the blind spot (optional). And it can help the driver keep a safe distance behind the vehicle in front. So it becomes an invaluable companion on the road and can be a guardian angel that saves the day in dangerous situations.





Vigilant calm zone

Wouldn't it be good to have a watchful companion by your side at all times? Someone who knows you well and intervenes only when it is absolutely necessary? That "someone" is ATTENTION ASSIST. Fitted as standard, it monitors your driving style and warns you that you are becoming drowsy or letting your attention slip. For a higher level of safety – and a lower pulse rate.

Integrated protection can't be retrofitted

It anticipates. So that you have a reliable companion in all situations, your E-Guard offers integrated protection from the outset. Long before the first design sketch, long before the vehicle is given its "face", our engineers are working on the complex task of perfectly harmonising the interaction between the effective protection offered by a safety vehicle, its increased weight, its adapted chassis, its modified control systems, and the benefits of an E-Class as well as comfort and everyday suitability. So that your E-Guard can guarantee something a retrofitted E-Class could never do: factory-built quality.

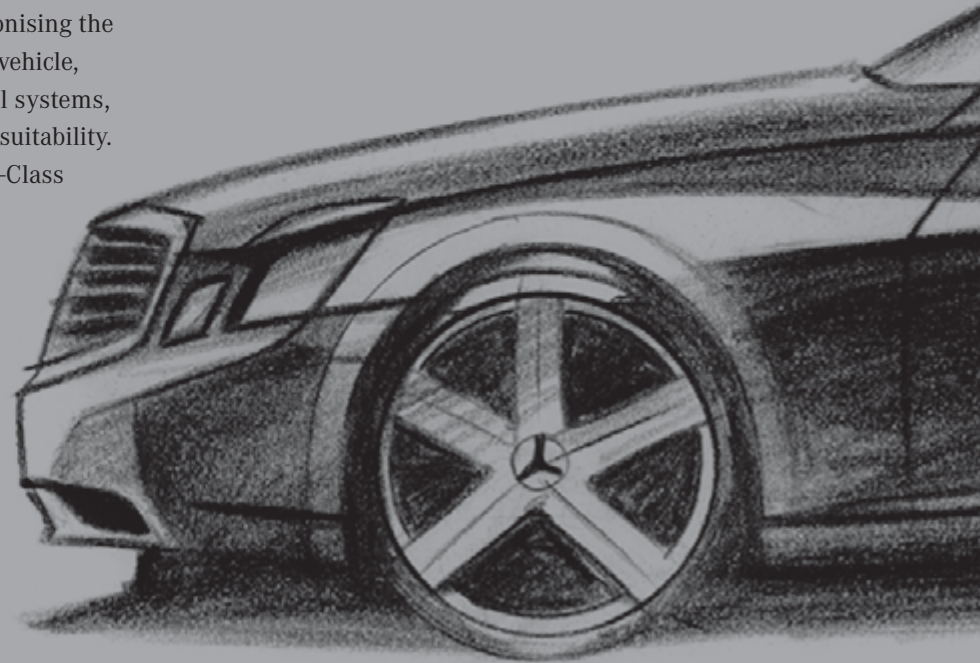

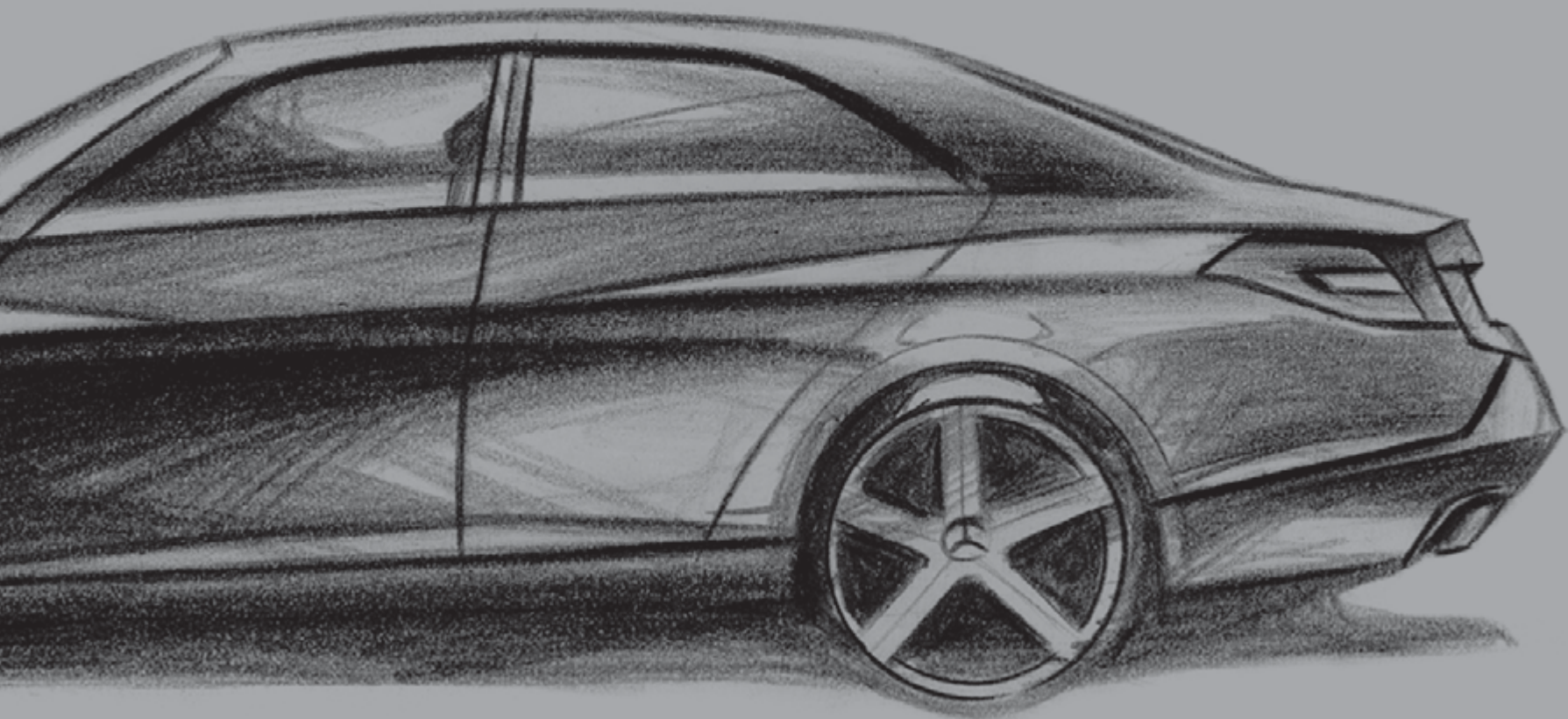



Our firm belief:

You can only discover the truth in severe endurance tests. Snow and ice, wet places and desert demand the highest performance of every vehicle – especially from a special protection vehicle that puts more dead weight on the road than a series-production saloon because of its additional protective components.

In high-speed tests we ensure that your E-Guard handles extreme situations just like a genuine Mercedes. Under diverse, most difficult road conditions we furnish complete proof: all electronic control systems from ABS to ESP® intervene at the right time to assist the driver optimally, including in critical situations. Each detail of the complete vehicle is properly matched to every other detail and designed for practicality, top performance and reliable durability – for your safety and your comfort.

An E-Guard sets standards

In crash tests too. It's comforting for you to know that owing to its special structural reinforcements your E-Guard is a safe place – in an accident, too. It has to prove itself in specific crash tests under the critical gazes of the engineers who develop the E-Guard; it has to show that the passenger compartment remains intact, it has to document that the restraint systems, from belt to airbag, afford excellent occupant protection, as convincing as in the E-Class.





We study the worst case. And chance

The list of ballistics testing methods is long. Not only the materials, the entire vehicle is subjected to intense testing. Surfaces, seams where different materials meet, functional joints such as in the door area: the entire vehicle is fired at, tested and challenged all around according to stringent standards and guidelines precisely defined by internationally recognised authorities. All the points that are taken under fire are determined by the Beschussamt, the official German ballistics agency.

What is more, this agency, and thus independent experts, systematically searches for possible weak points of the vehicle early on in production, when all protective components are visible, directing fire specifically at these points. They too must stand the test – there are no two ways about it.



Resistance classes according to BRV 2009

Class	Type of weapon	Projectile	Resistance
VR1			Weapons up to .22 LR
VR2			Handguns up to 9 mm Luger (Para)
VR3			Handguns up to .357 Magnum
VR4			Handguns up to .44 Magnum

VR = Vehicle Resistance

BRV = Guideline for the testing and certification of bullet-resistant vehicles



Your safe room. Officially tested

And, of course, certified. Your high-protection E-Guard is tested and certified in accordance with protection level VR4. This covers handguns such as the kind used in opportunistic crimes and street crime, including a .44 Magnum. The standard defines parameters such as projectile speed or distance between weapon and vehicle. The important result, for us and for you: the entire interior has bullet-resistant protection and is certified to VR4.

For your safety we go a crucial step further. To replicate reality as closely as possible, not only do we test at impact angles of 45° and 90°, we also take the door areas under random angles of fire to meet the stringent requirements of the official guideline BRV 2009. In addition, the E-Guard has to prove itself under triangulated fire and multi-hit tests as well to pass the multi-hit test according to its certification. This way we ensure that to the best of our knowledge the entire passenger compartment of the E-Guard is what it should be: your safe room.



E-Guard

Mercedes-Benz



Our answer to increased danger

More than the standard requires - this is not an end in itself for us, but serves solely for your protection out there in the real world. Accordingly we can fit your E-Guard with optional special floor armour. Its function: to protect the entire floor in the area of the passenger compartment and fuel tank. The special stainless steel used ensures that nothing that doesn't belong there can adhere magnetically. We've checked at various points that the floor armour fulfils its purpose reliably, even protecting against attacks with a DM51 hand grenade.

You don't see integrated protection

Discretion and unremarkableness characterise every E-Guard. And for a good reason, too. It should not be recognised as a special protection vehicle. Accordingly, we have hidden its unique network of protective components invisibly and perfectly under an outer skin identical to that of the series-production cars. The components we work with: innovative technologies and select materials, high-strength steel and intelligent material combinations, ingenious designs and overlapping systems. This gives you what you need: highly effective protection. From the bullet-resistant, splinter-proof glass ensuring highest visual quality, to the run-flat tyres. And as an added safety feature: discreetness.





Protection and comfort, intelligently combined

Integrated protection is precision work. So precise that you notice virtually nothing. Neither inside nor outside. Neither in the door areas nor in the feel of spaciousness. All the vehicle's protective components are shaped so exactly and are so perfectly integrated – like a second layer of skin – that the vehicle interior with its sense of spaciousness and its safety are fully intact. The chassis is strengthened in a targeted manner, and all dynamic handling systems are intelligently adapted. Airbags, restraint and control systems, countless innovations from the series-production vehicle are featured by the E-Guard and do their jobs just as attentively and without restrictions.



Individuality and personality

Design, equipment and appointments, comfort: everything that makes the E-Class so pleasant and inviting distinguishes the E-Guard too. We've left out nothing in your E-Guard. We've only added something very important: the exceptional art of protection, perfectly integrated. Whatever personal touch your E-Guard is to have, from the Exclusive package to designo to the ELEGANCE or AVANTGARDE lines: it's entirely up to you.







Mercedes-Benz Guard

Design, Equipment and Appointments, Comfort

Protection: E-Guard. Style: ELEGANCE

Refined elegance and distinctive comfort are the hallmarks of the ELEGANCE line. The E-Guard emphasises this personality trait quite like the E-Class. High-gloss chrome trim elements embellish the exterior. Select fabric and leather, fine trim and wood come together to create a harmonious interior, in colour and styling.

Designed as a comfortable 5-seater, the E-Guard impresses through spaciousness, no matter what appointments are chosen. When equipped with the optional floor armour, the vehicle features individual rear seats instead of the standard-fit rear bench seat.







Protection: E-Guard. Style: AVANTGARDE

The features that characterise the AVANTGARDE equipment line also distinguish your E-Guard. Its strikingly sporty, dynamic character sets the tone of the interior and exterior – from the shape of the seats to the athletic lines, consistently carried over even to the design of the wheels. As with the series-production cars you can place additional visual accents. The innovative paint system of Mercedes-Benz conjures up intense, lasting gloss in both non-metallic and metallic paint finishes. Fine wood and leather invite you to be choosy for the interior too. And designo gives you even more scope for individuality.





Exclusive package

The finest materials and elegant visual touches – the optional Exclusive package adds an extra aura of refinement to the high-quality interior of the ELEGANCE and AVANTGARDE lines.



INTERIOR

Black, beige or grey as interior colours

Dashboard and upper door panelling with high-quality trim and visible topstitching

Roof lining, pillars and sun visors in Alcantara® (in beige or grey)

Seats with nappa leather upholstery in black, beige or grey (gathered door centre panels)

Velour floor mats with nubuck strip in appointments colour

Our protection system: think of everything

The more intelligent the technology, the simpler its operation and the more reliable its effect: we've also designed the panic alarm system according to this maxim.

A push of a button suffices to activate the sophisticated system. It can be triggered from any seat in the E-Guard if danger is detected. Immediately, all doors are locked, the headlamps and turn indicators flash intermittently, accompanied by an acoustic signal. Without having to open the windows or doors, it is possible to talk to people around the car by means of an intercom system. A further special detail: the illuminated boot lid emergency opening facility. In



a jiffy one can free oneself from the boot at any time, even if the boot lid has been locked from the outside.

At first glance only a door. At second glance, a little masterpiece of special protection. Panes and window lifts are integrated in a special process. The front side windows are fully retractable; the rear side windows, almost. Front power windows are a standard feature.



A further special feature: the peak optical quality of the polycarbonate glazing on all windows, combining the best properties such as high strength, splinter-proofing and bullet resistance. The rear window, with window heating as standard, also enhances visibility in any weather. As an optional extra a heated windscreen is also available.



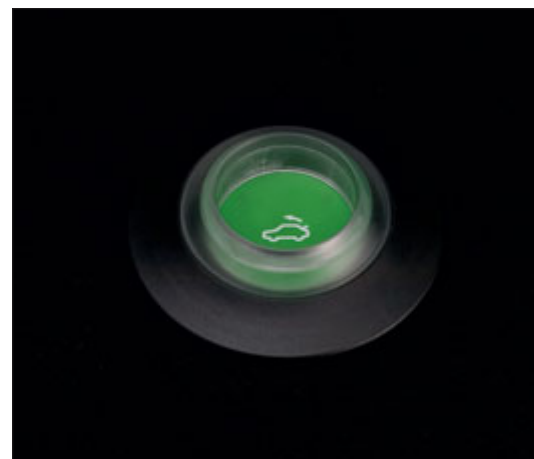

Four engine variants, every one a powerhouse

Torque, powerful, quiet and economical: the engine technology in the E-Guard offers effortlessly superior power and thus important safety reserves in any situation. The petrol-engine-powered E 500 BlueEFFICIENCY and E 350 BlueEFFICIENCY, and the diesel-engine driven E 300 CDI and E 350 CDI BlueEFFICIENCY impress with their powerful output.

V6 engines. The E 300 CDI developing 170 kW and the E 350 CDI BlueEFFICIENCY delivering 195 kW are equipped with V6 diesel engines. Precise and fast piezo injectors, a high injection pressure and a peak torque of 540 Nm for the E 300 CDI and 620 Nm for the E 350 CDI BlueEFFICIENCY all add up to effortlessly superior pulling power.

The E 350 BlueEFFICIENCY with V6 engine. Its rated output: 225 kW (306 hp) with a peak torque of 370 Nm.

The E 500 BlueEFFICIENCY with V8 engine. Traditionally this is the most powerful unit in the engine range of the E-Class. Its 300 kW (408 hp) develop a maximum torque of 600 Nm and accelerate the car from 0 to 100 km/h in 5.3 seconds.

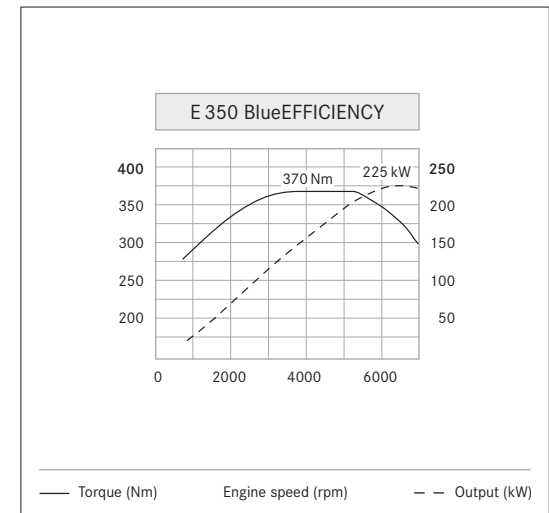



The 6-cylinder diesel engine is available with a choice of 3 outputs (E 350 CDI BlueEFFICIENCY pictured here)

The transmission: 7G-TRONIC PLUS

Whether it be an economical or a sporty driving style – the transmissions for the E-Class have been optimised in line with the model in which they are installed. In addition, they are intuitive and ergonomic to use.

7G-TRONIC PLUS. The V6 and V8 models are fitted as standard with the 7G-TRONIC PLUS 7-speed automatic transmission. The transmission is controlled using the DIRECT SELECT lever, while the shift paddles on the steering wheel enable the driver to influence the gear changes. Seven forward gears allow optimum engine speeds at all times, reducing fuel consumption. Compared to the 7G-TRONIC forerunner, the electrohydraulic control unit

has been further improved, the engine and transmission software optimised, all of which results in further enhanced gear-change dynamics and shift quality. What's more, the 7G-TRONIC PLUS responds more directly when the driver presses or releases the accelerator pedal.



Fingertip transmission control with the DIRECT SELECT lever on the steering column

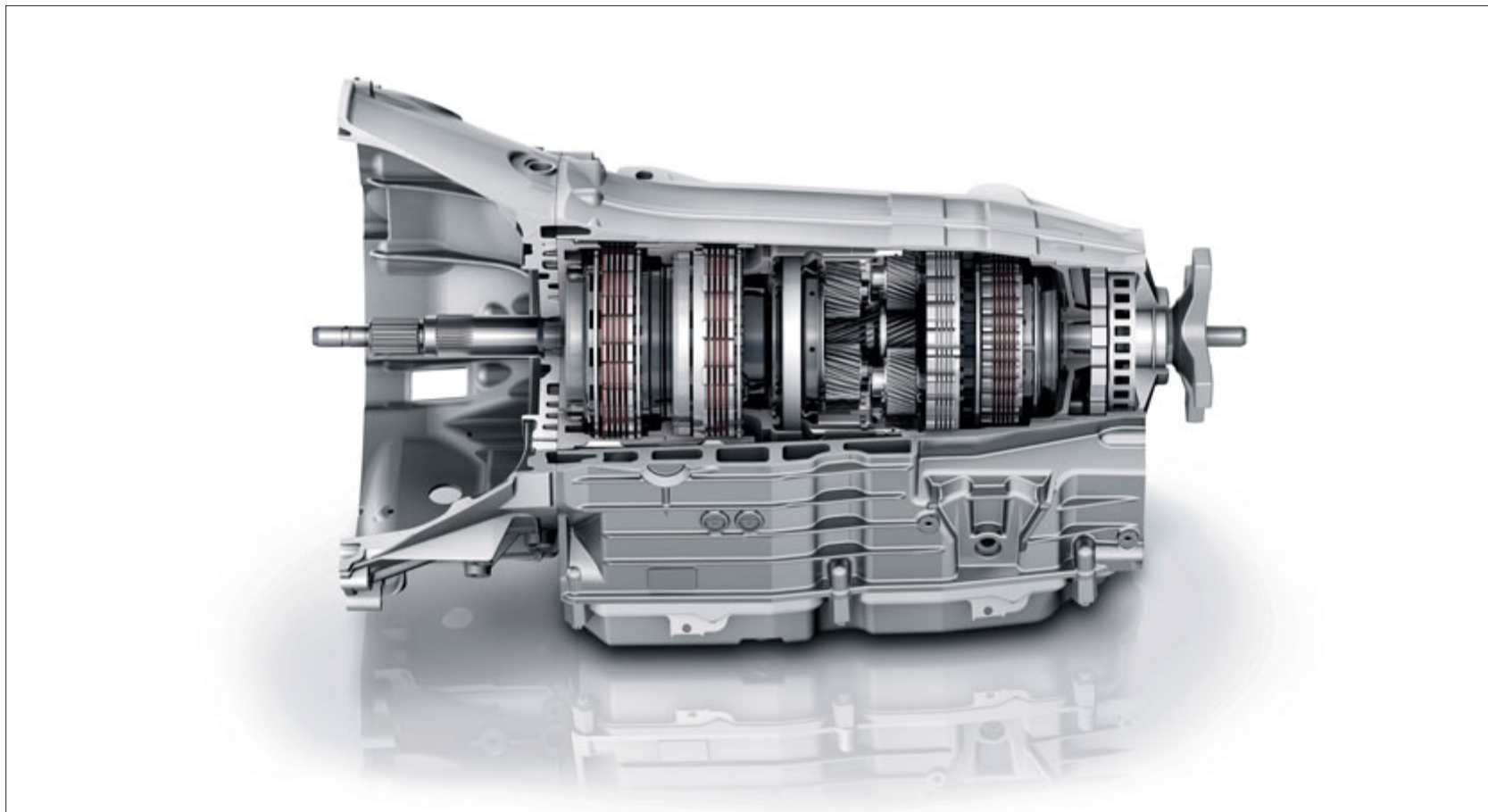

7G-TRONIC: one of over eleven million automatic transmissions produced in a period spanning more than 40 years

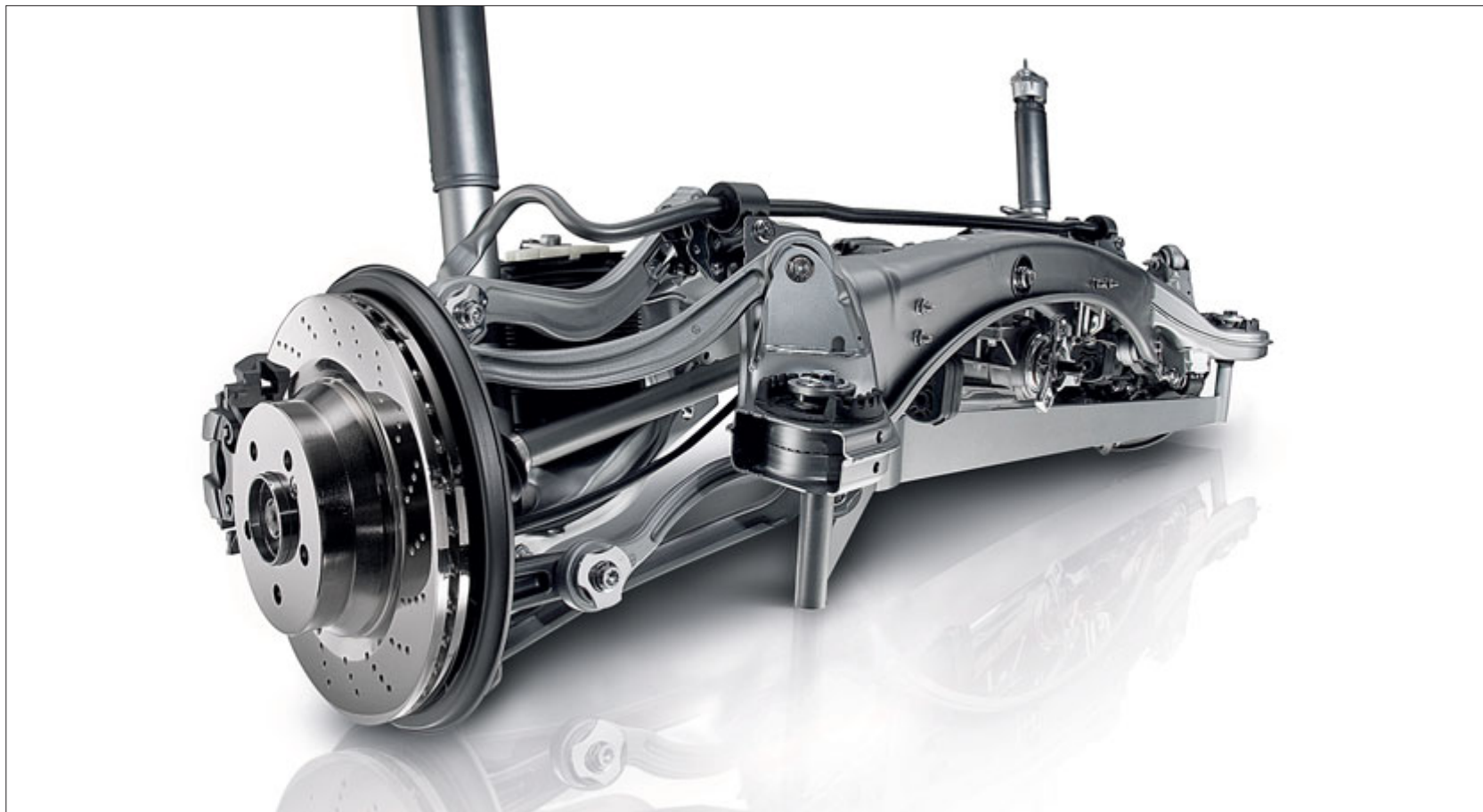

The suspension: optimally adapted to the added weight

The suspension: precisely adapted

Comfort and agility figure large in the E-Class. So that you do not have to do without them, we have adapted everything to the increased kerb weight of the E-Guard optimally: suspension, AIRMATIC, brakes, control systems. For highest ride comfort.

Direct-Steer system (standard). The Direct-Steer system has a more direct steering ratio and reduces the steering effort required in the case of large steering angles, for example when parking or taking tight bends, thus enhancing the car's agility and steering comfort.

AIRMATIC (integrated in all E-Guard models, standard for E 500 BlueEFFICIENCY). The AIRMATIC air suspension system, with adaptive shock absorbers, adapts itself automatically to the current road conditions, vehicle load and driving situation. The driver can also select comfort-oriented or sporty settings manually. The vehicle thus offers improved roadholding and more motoring enjoyment.

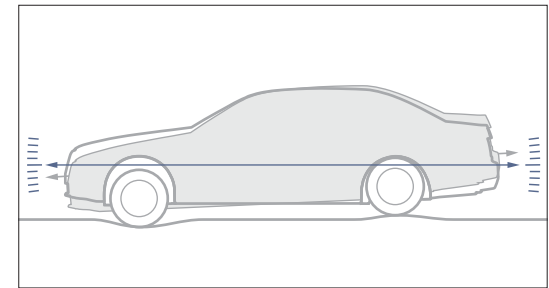

The AIRMATIC air suspension system maintains a constant ground clearance, even if the car is carrying a heavy load

The assistance systems: attentive companions

The assistance systems from Mercedes-Benz have one objective – more comfort, more safety while driving. Their innovative technology and attentiveness support the driver, including in critical situations, and thus make for relaxed motoring. All the assistance and control systems and their sensors are as fully effective in the E-Guard as they are in the E-Class, in spite of strong bulletproof glass and the higher vehicle weight.

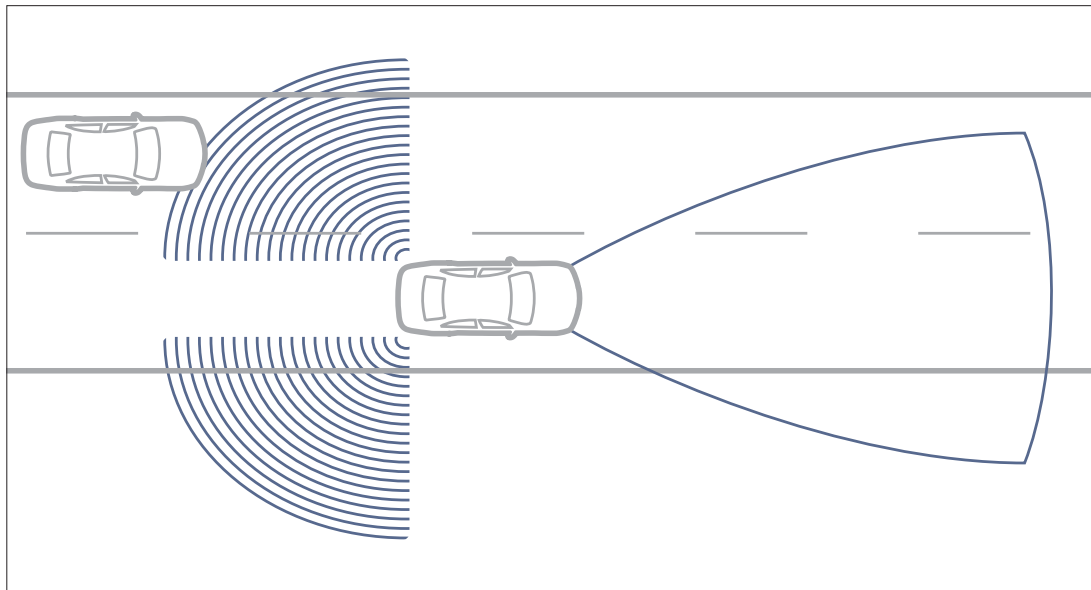

Lane Keeping Assist and Blind Spot Assist can warn the driver in potentially dangerous situations

Driving Assistance package. Various assistance systems are included in this package: Lane Tracking package, BAS Plus and the new PRE-SAFE® Brake, which can initiate autonomous partial and emergency braking when a head-to-tail collision threatens and thus acts as an electronic crumple zone. Also included: DISTRONIC PLUS, the proximity control that helps to maintain a desired distance to the vehicle ahead.

Lane Tracking package. Lane Keeping Assist detects the lane markings on the road. Discreet vibrations of the steering wheel warn the driver if the car leaves its lane unintentionally. Blind Spot Assist monitors the blind spot with two radar sensors at speeds above 35 km/h; it can warn the driver against dangerous lane changes.

ATTENTION ASSIST (standard). This drowsiness detection system is very useful on long trips. At speeds of between 80 and 180 km/h, it warns the driver when signs of drowsiness or inattention are detected. Sensors analyse driving behaviour and can detect deviations from a previously determined, individual driver profile.



If the driver shows signs of drowsiness, ATTENTION ASSIST recommends taking a break

Speed Limit Assist (optional). The system boosts safety by recognising traffic signs and showing the speed limit displayed on them in the cockpit. It is also capable of registering variable speed limit displays and speed limits put in place at short notice, such as, e.g. for road works.



Speed Limit Assist can also indicate temporary speed limits

PARKTRONIC including Parking Guidance (optional). Parking Guidance helps when finding a space and parking. The system uses data from ultrasound sensors to determine whether a space is adequate, and provides instructions on the correct steering angle and the points at which to turn or reverse to park with just a few steering-wheel movements.



Parking Guidance indicates suitable parking spaces to the driver and provides parking directions

Light package (optional). The package features bi-xenon headlamps and LED daytime running lamps, allowing numerous settings to optimise illumination. In the case of the active light function, the headlamps with dynamic range adjustment follow the driver's steering movements, thus ensuring up to 90% better illumination of all relevant areas. This can make driving at night safer, particularly on winding routes, as obstacles can be detected much earlier. Adaptive

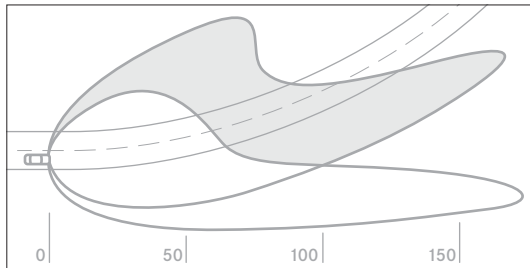

The active light function ensures far better illumination on both tight and long bends, even when driving with just low beam on

Highbeam Assist can improve visibility at night. If oncoming traffic or a vehicle in front is detected, it can dim the headlamps automatically. It also controls the headlamp beam so as not to dazzle these vehicles. The smooth transition from main beam to low beam also prevents any abrupt changes in the degree of illumination.

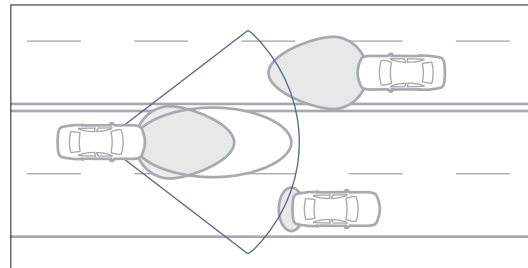

With Adaptive Highbeam Assist the transition between low and main beam is virtually seamless

Reversing camera. Good visibility during all parking and reversing manoeuvres: the reversing camera with wide-angle lens registers the area directly around the rear of the car and transmits the images to the central COMAND display. It is activated automatically when reverse is engaged, thus enhancing safety when reversing into a parking space.



The reversing camera's wide-angle lens monitors the area directly around the rear of the car

Night View Assist Plus (optional). The central display shows the entire area normally covered by main beam, as registered by the Night View Assist system's infrared camera, in the form of a greyscale image – making it easier for drivers to get their bearings in situations where main beam cannot be switched on and allowing them to react quicker to people, animals or objects detected on or next to the road.



To ensure even better visibility, Night View Assist Plus highlights pedestrians on the display

Multimedia systems

The E-Class offers a full range of entertainment systems, from the Audio 20 CD to the optional Audio 50 APS and the optional COMAND Online multimedia system.



COMAND Online is a combination of telephone, audio system and navigation system. It includes three years of free updates for your map data (vehicle-specific, from date of first registration)

Audio 50 APS. This entertainment system features DVD navigation with a 2-D map display and the Traffic Message Channel (TMC).

COMAND Online (optional). This multimedia system with hard disc navigation and optimised map display shows all information on a 17.8 cm central colour display. Functions include radio, an equaliser with speed-dependent volume control and the MUSIC REGISTER with a 10-GB hard disc. The DVD drive provides for perfect entertainment.

Harman Kardon® Logic 7® surround sound system. Featuring fourteen loudspeakers, including a woofer, this optionally available Dolby Digital 5.1 system has an output of 610 watts – for first-class acoustics.

Climate control

A pleasant interior climate is paramount when it comes to ensuring a high level of stress-relieving safety. This is why the temperature control system for the E-Class is exceptionally versatile and can be adjusted to meet the needs of each individual occupant.



The controls for the THERMOTRONIC luxury automatic climate control system are ergonomic and intuitive

THERMATIC (standard). The THERMATIC automatic climate control system uses sensors to control the temperature and ventilation for the driver and front passenger automatically. Further standard features include air recirculation, a cooled glove compartment and a combination filter (dust and activated charcoal filter) which filters out fine particles and improves overall air quality.

THERMOTRONIC (optional). THERMOTRONIC luxury automatic climate control (standard for V8 models) allows driver and front passenger each to set their own temperature – the rear passengers have their own control unit. What's more, automatic mode can be adapted to individual needs as there are three climate styles to choose from: **DIFFUSE**, **MEDIUM** and **FOCUS**.

Equipment (selection)

	E 300 CDI ¹	E 350 CDI BE ^{1,2}	E 350 BE ^{1,2}	E 500 BE ²
EQUIPMENT LINES				
AVANTGARDE line	●	●	●	■
ELEGANCE line	●	●	●	□
SPECIFIC SPECIAL PROTECTION EQUIPMENT				
Boot lid emergency opening switch inside boot	●	●	●	●
E-Guard High-Protection package consisting of:				
Front power windows on either side				
Protected passenger compartment, level VR4 (BRV 2009)				
Heated rear window	□	□	□	□
Safety glass with polycarbonate layer for splinter protection				
Specially reinforced suspension components and adapted control systems				
Floor armour 1x DM51 (only in conjunction with individual rear seats)	●	-	●	●
Heated windscreen	●	●	●	●
Panic alarm system including intercom	●	●	●	●
Rear power windows on either side	●	●	●	●
Tyres with run-flat capability	○	○	○	○



	E 300 CDI ¹	E 350 CDI BE ^{1,2}	E 350 BE ^{1,2}	E 500 BE ²
ASSISTANCE SYSTEMS				
Driving Assistance package (DISTRONIC PLUS, BAS PLUS, PRE-SAFE® Brake, Lane Tracking package incl. Blind Spot Assist and Lane Keeping Assist)	●	●	●	●
Lane Tracking package, including Blind Spot Assist and Lane Keeping Assist	●	●	●	●
Night View Assist Plus	●	●	●	●
PARKTRONIC incl. Parking Guidance	●	●	●	●
Reversing camera	●	●	●	●
Speed Limit Assist	●	●	●	●
EXTERIOR and SUSPENSION				
17-inch wheels incl. 245/45 R17 tyres with run-flat capability	○	○	○	-
18-inch wheels incl. 245/40 R18 tyres with run-flat capability	-	-	●	□
AIRMATIC	○	○	○	□
Compact spare tyre in place of TIREFIT tyre sealant	-	-	-	●
Fully fledged spare tyre with run-flat capability	○	○	●	-
Intelligent Light System with bi-xenon headlamps	●	●	●	●
Tyre pressure monitoring system	●	●	●	●

● Optional at extra cost ■ Optional at no extra cost ○ Obligatory at extra cost □ Standard - Not available ¹ Available for certain countries only ² BlueEFFICIENCY



Equipment (selection)

	E 300 CDI ¹	E 350 CDI BE ^{1,2}	E 350 BE ^{1,2}	E 500 BE ²
INTERIOR				
Active Multicontour seat package	●	●	●	●
Automatic child seat recognition in front passenger seat ³	●	●	●	●
Climatised front seats	●	●	●	●
DIRECT SELECT lever on steering column	□	□	□	□
Exclusive package includes nappa leather, Alcantara® roof lining, velour floor mats	●	●	●	●
Heated front seats	●	●	●	●
Heated rear seats	●	●	●	●
KEYLESS-GO package	●	●	●	●
Memory package: front seats, front head restraints, steering column and exterior mirrors electrically adjustable with memory function	●	●	●	●
Multicontour seat package	●	●	●	●
Rear Comfort package consisting of individual rear seats with luxury head restraints, leather upholstery, seat heating & Sun Protection package	●	●	●	●
Rear seats with integrated child seat	●	●	●	●
Sun Protection package	○	○	○	○

¹ Available for certain countries only ² BlueEFFICIENCY ³ Child seats with transponder specifically approved for Mercedes-Benz

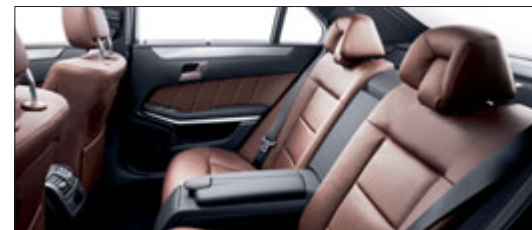
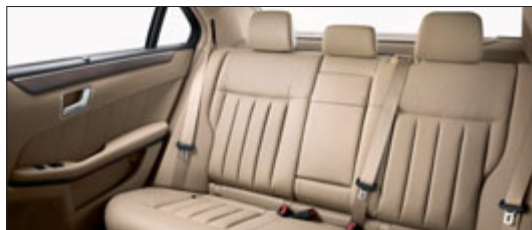

	E 300 CDI ¹	E 350 CDI BE ^{1,2}	E 350 BE ^{1,2}	E 500 BE ²
THERMATIC automatic climate control	<input type="checkbox"/>	<input type="checkbox"/>	<input type="checkbox"/>	-
THERMOTRONIC luxury automatic climate control	●	●	●	<input type="checkbox"/>
SAFETY				
Adaptive brake lights	<input type="checkbox"/>	<input type="checkbox"/>	<input type="checkbox"/>	<input type="checkbox"/>
Active bonnet	<input type="checkbox"/>	<input type="checkbox"/>	<input type="checkbox"/>	<input type="checkbox"/>
Airbags with multi-stage deployment logic for driver and front passenger, sidebags for driver and front passenger; Windowbags for driver, front passenger and rear passengers, kneebag	<input type="checkbox"/>	<input type="checkbox"/>	<input type="checkbox"/>	<input type="checkbox"/>
Anti-theft protection package	●	●	●	●
Head restraints (5), adjustable, with crash-responsive NECK-PRO head restraints in the front	<input type="checkbox"/>	<input type="checkbox"/>	<input type="checkbox"/>	<input type="checkbox"/>
PRE-SAFE® system	<input type="checkbox"/>	<input type="checkbox"/>	<input type="checkbox"/>	<input type="checkbox"/>
Rear Seat Safety package	●	●	●	●

● Optional at extra cost ○ Obligatory at extra cost Standard - Not available ¹ Available for certain countries only ² BlueEFFICIENCY

Some items of equipment are not available on account of the protection concept: trailer coupling, glass roof, sliding glass roof, EASY-PACK boot box, suspension variants, 16" or 18" wheels, ski bag, through-loading feature, standard equipment package (Code 953)

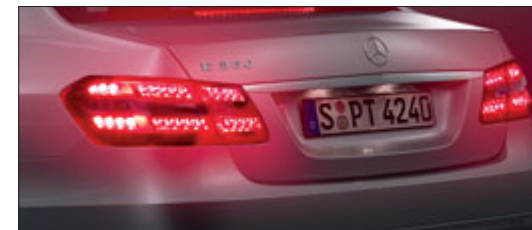

	E 300 CDI ¹	E 350 CDI BE ^{1, 2}	E 350 BE ^{1, 2}	E 500 BE ²
ENTERTAINMENT AND COMMUNICATION				
Audio 20 CD	<input type="checkbox"/>	<input type="checkbox"/>	<input type="checkbox"/>	<input type="checkbox"/>
Audio 20 CD incl. CD changer	●	●	●	●
Audio 50 APS (map navigation)	●	●	●	●
Audio 50 APS radio with integrated 6-disc DVD changer and LINGUATRONIC	●	●	●	●
COMAND Online (map navigation)	●	●	●	●
COMAND Online (map navigation) with integrated 6-disc DVD changer	●	●	●	●
Convenience Telephony	●	●	●	●
Digital/analogue TV tuner	●	●	●	●
Digital radio (DAB)	●	●	●	●
Harman Kardon® Logic 7® surround sound system	●	●	●	●
Media Interface	●	●	●	●
Rear Seat Entertainment System	●	●	●	●

● Optional at extra cost Standard ¹ Available for certain countries only ² BlueEFFICIENCY





E-Guard technical data

	E 300 CDI ¹	E 350 CDI BlueEFFICIENCY ¹	E 350 BlueEFFICIENCY ¹	E 500 BlueEFFICIENCY
No. of cylinders/arrangement	6/V	6/V	6/V	8/V
Total displacement (cc)	2987	2987	3498	4663
Rated output (kW at rpm) ²	170/3800	195/3800	225/6500	300/5000–5750
Acceleration from 0–100 km/h (s)	7.8	6.7	6.9	5.3
Top speed, approx. (km/h) ³	240	240	240	240
Fuel consumption (l/100 km) ⁴				
Combined	7.2	6.7	7.7	9.6
CO ₂ emissions (g/km) ⁴ combined	188	176	181	225
Emission class	Euro 4	Euro 5	Euro 5	Euro 5
Payload (kg)	475	475	545	435

All models only available with automatic transmission.

¹ Available for certain countries only ² Figures according to Directive 80/1269/EEC in the currently applicable version ³ Electronically limited ⁴ The figures shown were obtained in accordance with the prescribed measuring process (Directive 80/1268/EEC in the currently applicable version). The figures are not based on an individual vehicle and do not constitute part of the product offer; they are provided solely for the purposes of comparison between the different vehicle models

E-Guard dimensions

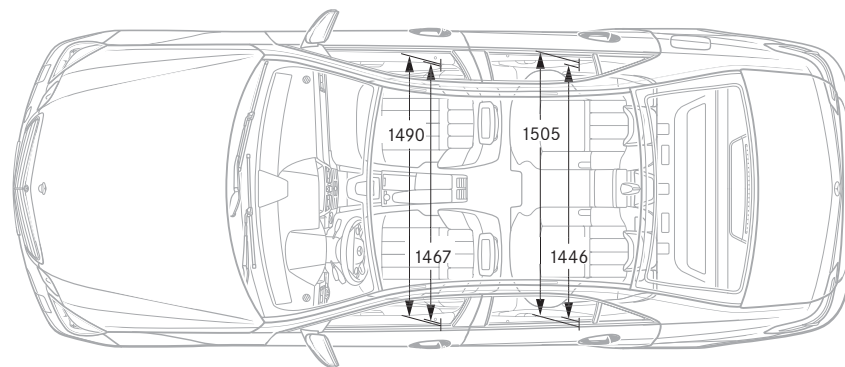
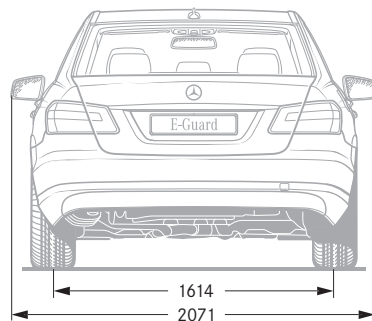
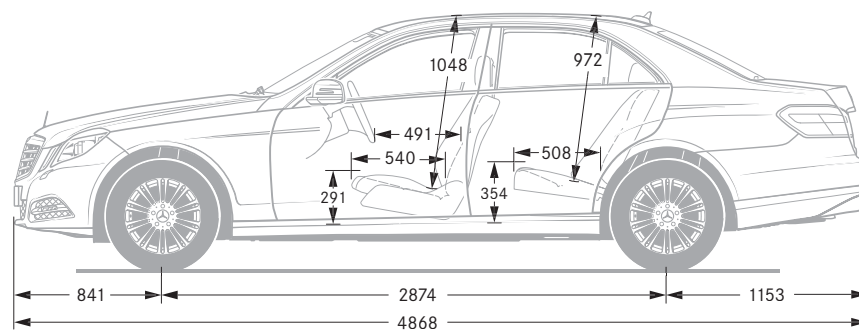
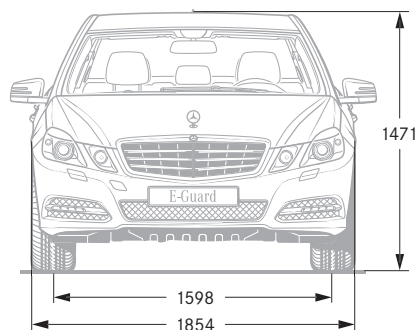

All measurements in millimetres. The dimensions shown are mean values and apply to standard-specification, unladen vehicles

Factory warranty and worldwide service

Mercedes-Benz mobility. Your new car comes complete with the promise of feeling safe on the road, but if you should ever need assistance, then Mercedes-Benz Service24h is there to help. Just call the freephone service hotline on 00800 1 777 7777¹. The newly integrated telematics service, Mercedes-Benz Contact², is even more customer-friendly: a touch of a button is all it takes to contact the Mercedes-Benz customer centre. If you wish, the relevant vehicle and position-related data can be transmitted at the same time, thereby allowing the centre to react quickly and provide rapid on-the-spot assistance. Also standard with your new car at no extra charge is the Mercedes-Benz Mobilo³ mobility package. Whether you have lost your key, had a breakdown which cannot be repaired immediately or suffered damage to the vehicle due to an accident or vandalism, Mobilo is there to help you reach your destination – anywhere in Europe. Whatever your problem, one thing is certain: you will soon be able to resume your journey.

Service packages. Vehicle-specific services allow you to put together an individual package for your Mercedes, including long-term protection against unforeseeable repair costs and high-quality servicing with genuine Mercedes-Benz parts. You can also count on the extensive network of Mercedes-Benz workshops, where you will receive the usual high standard of service for your Mercedes at a predictable, fixed price. Please ask your Mercedes-Benz dealer for further details.

Test drive. The unique feeling of driving a Mercedes cannot be put into words. Which is why we'd like to invite you to experience it for yourself. Take a test drive and find out first hand how it feels to drive your dream car. Simply visit www.mercedes-benz.com to locate the nearest Mercedes-Benz dealer in your country or region.

Interactive Owner's Manual. The website also offers an interactive tour, enabling you to take a closer look at your desired model. These informative clips are the ideal way to acquaint yourself with your dream car. You can view key functions in detail, gain an insight into the car's inner workings or look at the benefits of each model. For further details, go to: www.mercedes-benz.de/owners-manual

Mobile internet. Now you can access the entire world of Mercedes-Benz from your mobile phone. As well as an overview of all the passenger car models, there are insights into the entire brand world along with a wealth of entertainment offers and direct links to our range of services at www.mercedes.mobi

¹ Alternative: +49 69 95 30 72 77 ² Requires a factory-fitted radio, connected to an operational mobile phone ³ Once the warranty has expired, Mobilo can be extended in periods of one year for a maximum of 30 years, provided that regular maintenance is carried out by your Mercedes-Benz service partner



Your authorised Mercedes-Benz dealer will be pleased to give you more information.

We're there for you. Can there be a better promise?

Please note: changes may be made to this product brochure at any time. The manufacturer reserves the right to make changes to the design, form, colour and specification during the delivery period. Where the vendor or the manufacturer uses symbols or numbers to describe an order or the subject of an order, no rights may be derived solely from these. The illustrations may show items of equipment which are not part of standard specification. Colours may differ slightly from those shown in the brochure, owing to the limitations of the printing process. This brochure has been compiled by Daimler AG of Germany and is distributed internationally. For current information in relation to the product and its equipment, you should contact your nearest authorised Mercedes-Benz Passenger Car Dealer.
www.mercedes-benz.com/guard