



Pulse-quickenning
Heart-pounding
All-American
Legend.

Technology by itself does not make a great sports car. It takes heart and soul. Welcome to the Corvette story, 1995 edition.

The mystery

The motivation

The desire

The dream





You've wanted one for as long as you can remember. Make this your year to own America's favorite sports car.

Corvette Coupe

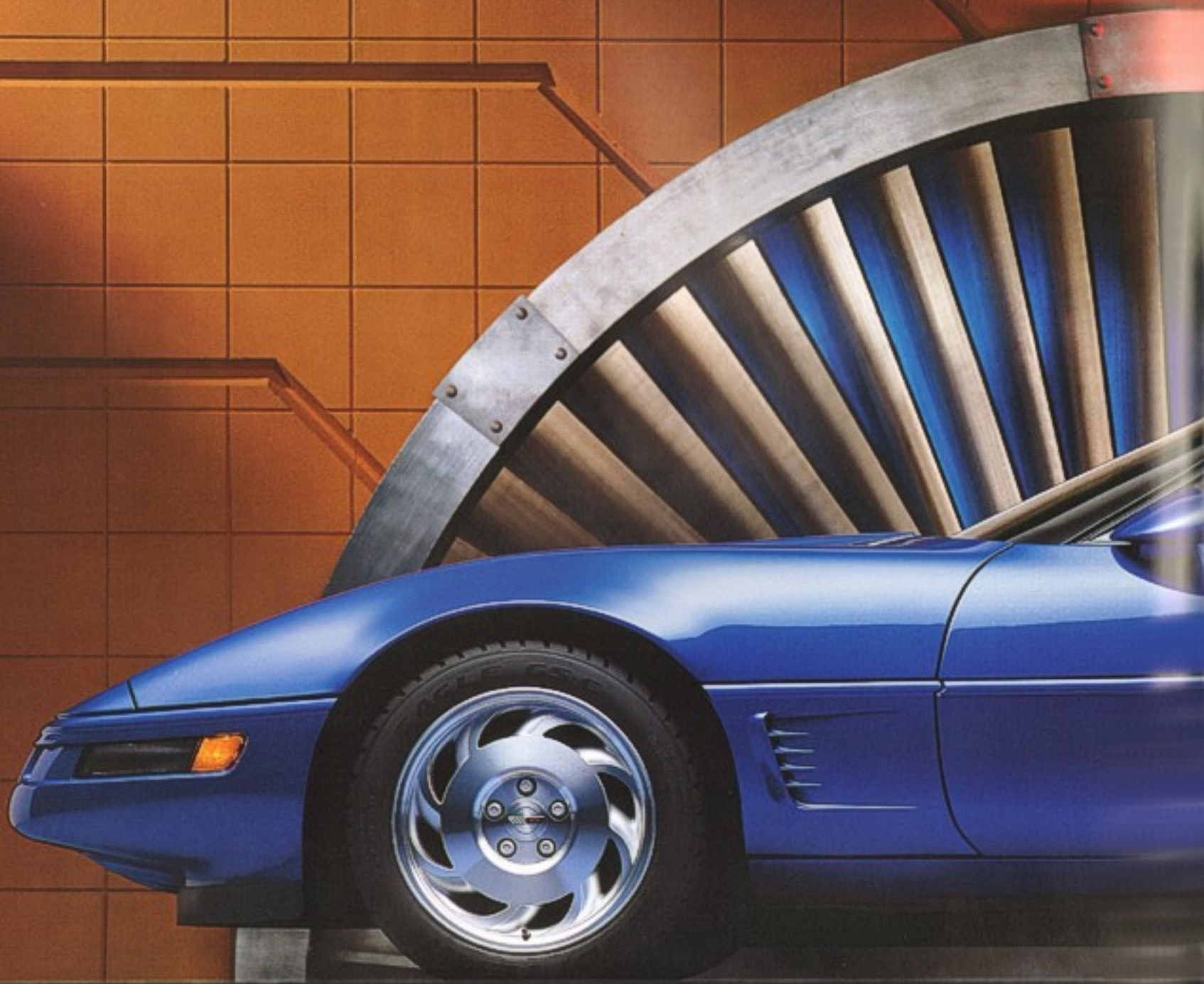



Corvette Convertible







Corvette ZR-1 Coupe





UNLEADED FUEL ONLY



DIMMER

WIPER OFF DELAY PUSH

L O R

L R

The command

The control

The feel.



Race car-inspired gauges and controls are grouped directly in front of you. The instrument panel sweeps around, cockpit-style, and the leather-wrapped steering wheel adjusts to enhance your driving comfort. This is functional luxury for the enthusiast, as only Corvette can deliver.



The image shows the interior of a car, specifically the driver's side. The seats are made of tan leather with a bucket seat design. The dashboard and center console are black. The car is parked on a brick surface. The text is written in a cursive font in the upper right corner.

Comfortable

Ergonomic

Beautiful

You can choose from two Corvette interiors. Our designers call this one "classic Corvette." The luxurious, contoured bucket seats envelope you in leather and are available with an optional six-way power adjuster. Standard conveniences include power windows with a driver's Express-Down feature, soft-glow courtesy lighting, and a unique-to-Corvette Passive Keyless Entry system that automatically locks or unlocks doors.

COMPACT
DISC
DIGITAL AUDIO

SCV — VOL

L H



OFF

PROG — RCL

BASS — TREB



+

FADE



R



TUNE



AUTO

AM
FM

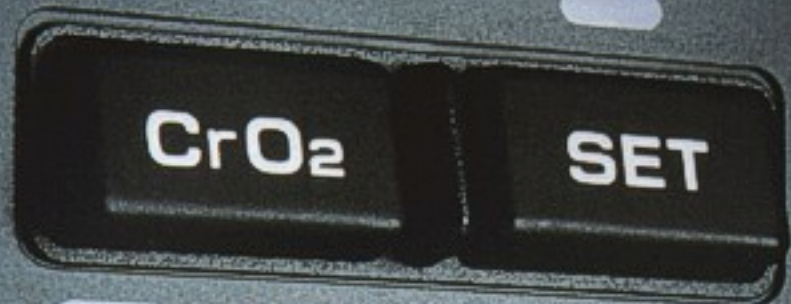

CrO₂

SET



CA/CD



DOLBY B NR



ST



STOP
PLAY



EJECT

*Dimensional
Sensational
Performance*

TRACK

CD IN SCV

1

REV

2

FF

3

COMP

4

REPT

5

SRCH

6

SCAN

Delco

BOSE

A Delco AM/FM stereo with cassette tape player is standard in Corvette Coupe and Convertible. Features of this high-performance stereo include four speakers tuned to the acoustics of each body style, a power antenna and a digital clock.

The powerful Delco/Bose Gold Series AM/FM stereo with cassette tape player is optional. This system includes six tuned Bose speakers with 200 watts of natural sound, and a cassette tape player with auto-reverse. Optional in Corvette Coupe and Corvette Convertible.

Corvette's top-of-the-line sound system, the Delco/Bose Gold Series with compact disc player and cassette tape player, is standard in the ZR-1 and optional in other models. In addition to the features of the stereos listed above, this six-speaker system features automatic Speed-Compensated Volume: the faster you go, the louder the volume.

A delay feature for the accessories — which continues to supply power to the stereo and power windows after you turn the ignition key to "Off" and until you open a door — is standard in every Corvette.





Supple

Sumptuous

Form-fitting

Laterally correct.

The optional Corvette Sport interior is a dramatic blend of ultra-contemporary style and form-fitting comfort. Aggressively contoured, leather-trimmed seats are complemented by matching duo-tone door panel trim. Six-way power seat controls and power lumbar support are featured.



Seamless
Sophisticated
Powerful.

Forty years ago Chevrolet shook the sports car hierarchy with the introduction of a revolutionary V8 engine in the 1955 Corvette. Its creators couldn't have imagined it at the time, but this lightweight, high-revving V8 would go on to power more street cars and more race cars than any other engine in automotive history.

The already-legendary LT1 V8 that powers the 1995 Corvette is a direct descendant of the classic '55 "small-block" V8. The technical progress has been relentless — including advanced materials, electronic engine management systems, fuel delivery, and emissions controls — the Corvette LT1 sets an impressive standard for V8 performance.

LT1 V8 specifications — Displacement: 5.7 Liters. Induction system: Sequential-Port Fuel Injection. Aluminum cylinder heads. Computer-controlled ignition timing. Serpentine accessory drive belt. Horsepower (SAE net): 300 at 5000 rpm. Torque (SAE net): 340 at 4000 rpm. Redline: 5700 rpm. Compression ratio: 10.4:1.



Extended Mobility tires.

These Goodyear Eagle GS-C EMT tires, first seen on the 1994 Corvette, are optional on both Coupe and Convertible. With EMTs, you can drive up to 200 miles at 55 mph on completely deflated tires, so chances are you'll never change a tire at the side of the road again.

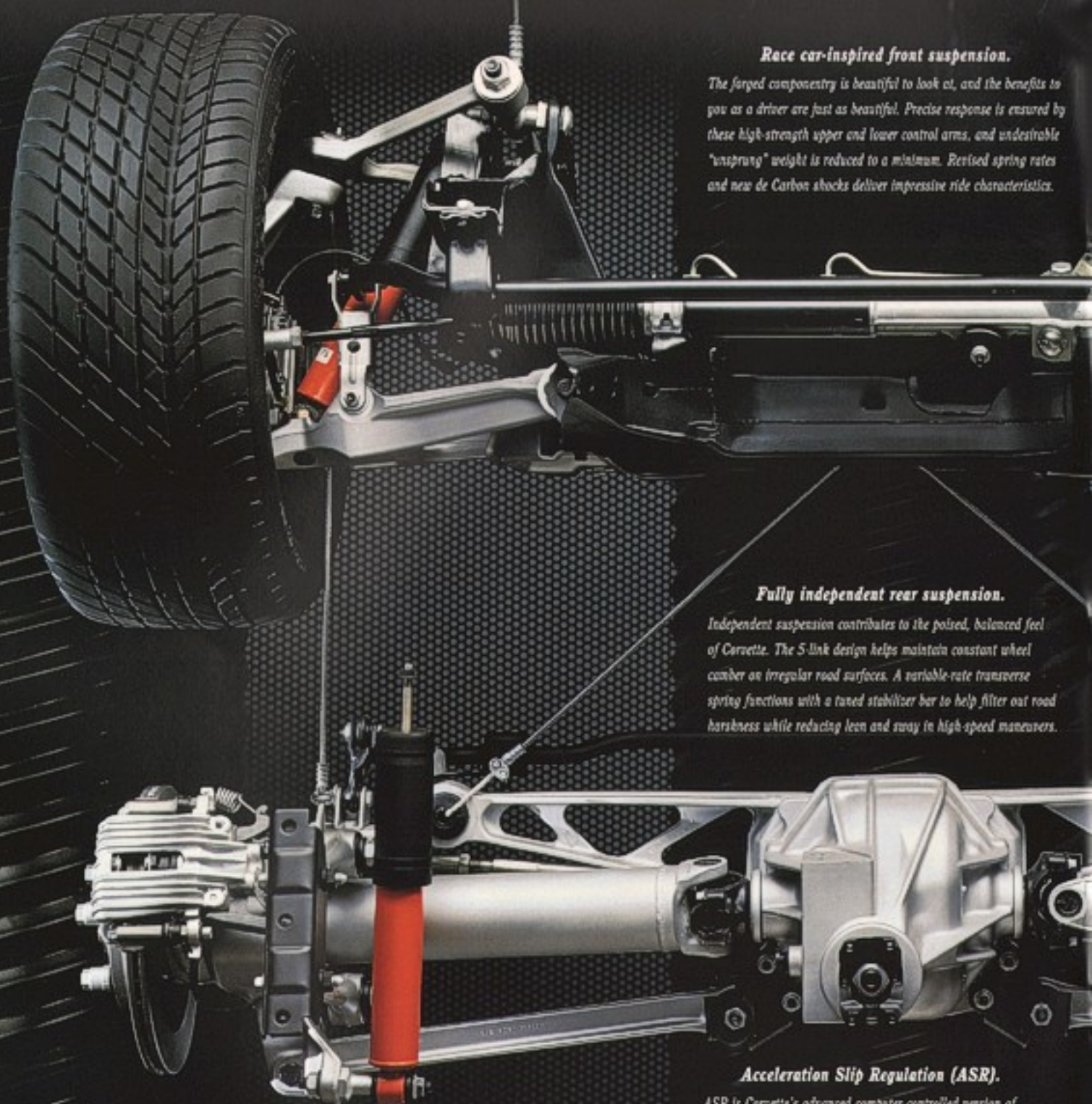

Race car-inspired front suspension.

The forged componentry is beautiful to look at, and the benefits to you as a driver are just as beautiful. Precise response is ensured by these high-strength upper and lower control arms, and undestructible "unsprung" weight is reduced to a minimum. Revised spring rates and new de Carbon shocks deliver impressive ride characteristics.

Fully independent rear suspension.

Independent suspension contributes to the poised, balanced feel of Corvette. The 5-link design helps maintain constant wheel camber on irregular road surfaces. A variable-rate transverse spring functions with a tuned stabilizer bar to help filter out road harshness while reducing lean and sway in high-speed maneuvers.

Six-speed manual transmission.

This delightful gearbox is a no-cost option in Corvette Coupe and Convertible. An equally sophisticated, electronically controlled 4-speed automatic is standard.

Acceleration Slip Regulation (ASR).

ASR is Corvette's advanced computer-controlled version of "traction control" which provides optimized acceleration and enhanced vehicle directional stability. When wheel slip is detected, the ASR system pulses the anti-lock brakes and momentarily reduces engine output via engine spark retardation and throttle control until traction is restored. An "on" or "off" switch is provided.



Four-wheel ABS.

You expect a car with Corvette's performance potential to have a world-class braking system, and Corvette does not disappoint. Standard: four-wheel heavy-duty disc brakes and an advanced Bosch four-wheel anti-lock brake system. ABS is designed to improve: *Controllability* — the ability to stop in a straight line, and *Steerability* — the ability to steer around obstacles while braking, especially on low-traction surfaces.

Quick

Agile

Responsive.

While test track data confirms the awesome power of the LT1 V8, the numbers only hint at the capabilities of the 1995 Corvette.

Advanced technology makes this an uncommonly balanced sports car for the real world, one that's as adept on a twisting two-lane back road as it is on an Interstate highway. In fact, even the daily commute is something terrific when you're at the wheel of a Corvette.

Take a moment to examine the hardware that puts Corvette in a class of exactly one.



CORVETTE

ZR-1



*Undefeated
Undisputed
All-American
Supercar.*

A glorious chapter in Corvette history comes to a close with the 1995 edition of ZR-1. For this will be the last in the six-year series of this very limited production, 405-hp Corvette. During its tenure as America's own exotic, ZR-1 has demonstrated that super car performance can co-exist with civility, refinement, and reliability. The big question: Could the 1995 be the most collectible ZR-1 of all? Wait too long, and you'll miss this moment in Corvette history.



The all-aluminum
32-valve
Double Overhead Cam
LTS

Others have chased the legend, but they've always come up short. Just turn the exclusive-to-ZR-1 "Power Key" to the Full setting, and you'll know why. With 32 valves, four overhead camshafts and the full potential of the LTS V8 at your command, everything else seems commonplace.

LTS V8 specifications — Displacement: 5.7 Liters. Induction system: Sequential-Port Fuel Injection. Aluminum engine block and cylinder heads. Four overhead camshafts. Four valves per cylinder (total 32). Computer-controlled ignition timing. Serpentine accessory drive belt. Horsepower (SAE net): 405 at 5800 rpm. Torque (SAE net): 385 at 5200 rpm. Redline: 7200 rpm. Compression ratio: 11.0:1.



4 CAM 32 VALVE

4 CAM 32 VALVE

CORVETTE

Safe
Secure
Advanced
Active.

There is really no subject more important than safety, and that's why the 1995 Corvette is a showcase of advanced GM technology. Dual air bags and four-wheel ABS are only a part of this safety package. Front and rear crush zones are designed to absorb energy in a collision and work in conjunction with a reinforced structure (including high-strength side frame rails and side-door beams) that surrounds the passenger compartment to help protect Corvette occupants.

PASS-Key II is a totally passive theft-deterrent system that is designed to help keep your new Corvette safe and secure. Only your special ignition key starts your 1995 Corvette. A horn alarm is also standard.

General Motors is the industry leader in air bag technology. In the '95 Corvette air bag system, even the air bag sensor contacts are gold-plated to enhance durability. And the air bag system contains self-diagnostics that require no annual inspection.

Responsiveness to driver input is an integral part of this safety story. With standard four-wheel ABS and ASR, an advanced traction-control system, Corvette helps you avoid collisions before they can happen.





Standard dual air bags.

The driver- and passenger-side air bags supplement the protection of safety belts in certain moderate to severe frontal collisions. Remember to always wear safety belts, even with air bags.

Bosch ABS 5.

This Bosch ABS is one of the most advanced four-wheel anti-lock brake systems available, and it is standard in every 1995 Corvette. Bosch ABS 5 is combined with four-wheel power discs for up to 1.0g of stopping power.

Safety-cage construction.

Corvette is actually a steel safety cage surrounding you. Front and rear crash zones help dissipate crash forces before they reach the passenger compartment.

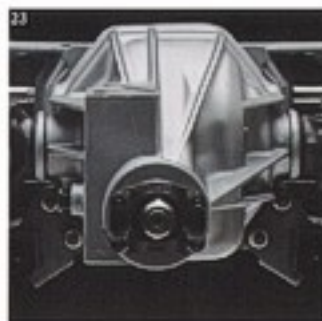

1 Six-way power seats are optional on Coupe/Convertible and standard on ZR-1.

2 A body-color removable roof panel is standard on Corvette Coupe, and a tinted glass panel is optional.

3 The optional body-color removable hardtop adds to the all-weather appeal of Corvette Convertible.

4 Front cornering lamps and halogen fog lamps are standard on all models.

5 The steering wheel is leather-wrapped and adjusts to four positions.

6 Electronic temperature control for the air conditioning is optional on Coupe and Convertible and standard on ZR-1.

7 The electronically controlled 4-speed automatic transmission is standard on Coupe and Convertible

(not available on ZR-1)

8 The 6-speed manual transmission is a no-cost option (standard on ZR-1).

9 GM's innovative PASS-Key II theft-deterrent system is standard.

10 A rear-window defogger is standard on all models.

11 Remote Passive Keyless Entry, standard, locks and unlocks doors for you automatically.

12 Heated, power sport mirrors are a nice convenience feature. Standard.

13 Selective Ride Control lets you select from three ride settings (Touring, Sport, and Performance). In each setting, ride firmness increases with speed. Optional on Coupe and Convertible, standard on ZR-1.

14 Optional Sport seats include power six-way adjustment and lumbar support (standard on ZR-1).

15 Driver and passenger air bags are standard.

16 Optional Delco/Bose stereo features both a CD player and cassette tape player (standard on ZR-1).

17 Z07 handling package is a Coupe-only option for specialized use only. See your dealer for equipment information.

18 Courtesy lamps are located in door panels, instrument panel and rear compartment.

19 The Convertible's folding top features a glass rear window and electric defogger.

20 Acceleration Slip Regulation (traction control) is standard, enhances performance in wet weather conditions.

21 Optional tire-pressure warning system illuminates instrument panel red/white light if pressure in any tire drops below 25 psi.

22 Optional Extended Mobility Tires will "run flat" for up to 200 miles.

23 Performance axle ratio is optional with automatic transmission, standard with 6-speed manual.

24 Two lockable in-car storage areas are featured.

25 A sophisticated four-wheel anti-lock brake system (ABS) is standard in every Corvette.

EXTERIOR	CPE	CNV	ZR-1
Base cost/clear coat paint	S	S	S
Compression proof fiberglass body panels	S	S	S
Dual electric remote-controlled heated sport mirrors	S	S	S
Dual halogen fog lamps	S	S	S
Front cornering lamps	S	S	S
One-piece removable roof panel	S	—	S
Removable hardtop	—	O	—
Retractable halogen headlamps	S	S	S
Tinted and flush-mounted glass	S	S	S
Transparent roof panel	O	—	O

INTERIOR	CPE	CNV	ZR-1
Air bags, (driver-side and passenger-side)	S	S	S
Air conditioning	S	S	—
Air conditioning (Electronic Control)	O	O	S
Day/night rearview mirror with integral map light	S	S	S
Electric rear window defogger	S	S	S
Electronic speed control	S	S	S
Full instrumentation with analog and digital display	S	S	S
Headlamps on reminder	S	S	S
Illuminated dual view mirrors	S	S	S
Intermittent windshield wipers	S	S	S
Leather-wrapped steering wheel	S	S	S

PASS-Key II theft-deterrent system	S	S	S
Power door locks	S	S	S
Power windows with driver's Express Down feature	S	S	S
Remote Passive Keyless Entry system	S	S	S
Scotchgard™ Fabric Protector (on floor carpeting and floor mats)	S	S	S
Seats, leather seating surfaces	S	S	—
Seats, Sport, leather seating surfaces	O	O	S
Seats, power six-way adjustable	O	O	S
Theft-deterrent horn alarm	S	S	S
Tilt Wheel™ Adjustable Steering Column	S	S	S

POWER TRAIN/CHASSIS/MECHANICAL	CPE	CNV	ZR-1
5.7 Liter I-175 V8 engine with Sequential Port Fuel Injection and aluminum cylinder heads	S	S	—
5.7 Liter L75 32 valve V8 with four overhead camshafts, all-aluminum construction and Sequential Port Fuel Injection	—	—	S
6-speed manual transmission	O	O	S
4-speed automatic transmission	S	S	—
Z07 Performance Handling Package (includes 17" x 9.5" wheels and P275/40ZR-17 tires)	O	—	—

(continued)	CPE	CNV	ZR-1
Acceleration Slip Regulation (Traction Control)	S	S	S
Bosch ABS 5 four-wheel anti-lock brake system	S	S	S
Electric in-tank fuel pump	S	S	—
Electric in-tank fuel pumps (2)	—	—	S
Fully independent suspension with transverse front and rear springs	S	S	S
Limited-slip differential	S	S	S
Power rack and pinion steering	S	S	S
Power steering cooler	S	S	S
Selective Ride Control	O	O	S
Aluminized stainless steel exhaust system	S	S	S

WHEELS/TIRES	CPE	CNV	ZR-1
Wheels, 17" x 9.5" aluminum (front)	S	S	—
17" x 9.5" aluminum (rear)	—	—	S
Wheels, 12" x 9.5" aluminum (front)	—	—	S
12" x 11" aluminum (rear)	—	—	S
Tires, Goodyear Eagle GS-C (P235/45ZR-17 front)	S	S	—
(P235/40ZR-17 rear)	—	—	S
Tires, Goodyear Eagle GS-C (P275/40ZR-17 front)	—	—	S
(P315/35ZR-17 rear)	—	—	S
Tires, Goodyear Eagle GS-C EXT Extended Mobility (requires low tire pressure warning system)	O	O	—

DELCO ELECTRONICS ETR SOUND SYSTEMS	CPE	CNV	ZR-1
Delco AM/FM stereo with cassette tape player, power antenna and digital clock	S	S	—
Delco/Bose AM/FM stereo with cassette tape player, power antenna and digital clock	O	O	—
Delco/Bose AM/FM stereo with cassette tape player, compact disc player, power antenna and digital clock	O	O	S

EXTERIOR DIMENSIONS (in.)	CPE	CNV	ZR-1
Wheelbase	96.2	96.2	96.2
Length (overall)	178.5	178.5	178.5
Width (overall)	70.7	70.7	73.1
Height	46.3	47.3	46.3
Tread width — front	57.7	57.7	57.7
Tread width — rear	59.1	59.1	60.6

INTERIOR DIMENSIONS (in.)	CPE	CNV	ZR-1
Head room	36.5	37.0	36.5
Leg room	42.0	42.0	42.0
Shoulder room	53.9	53.9	53.9
Hip room	50.8	50.8	50.8

CAPACITIES	CPE	CNV	ZR-1
Passenger capacity	2	2	2
Cargo capacity (cu. ft.)	12.6	6.6	12.6
Fuel tank (gal.)	20.0	20.0	20.0

S — Standard O — Optional

The choices

The options

The details

The works

As you can see, Corvette for 1995 has a most impressive list of standard features. However, there are a few things you can add, which makes choosing your new Corvette all the more exciting.

The color

Competition Yellow

Arctic White

Torch Red

Bright Aqua
Metallic

Dark Red
Metallic

Admiral Blue
Metallic

Polo Green II
Metallic

Dark Purple
Metallic

Black

The fabric

The Corvette Convertible features a glass rear window with standard electric defogger.

Convertible top color choices:

Black (fabric)

Beige (fabric)

White (vinyl)



The leather

The style



Luxurious leather seating surfaces are standard in all models.



Recommended Exterior/Interior Color Combinations

<i>Exterior Colors</i>	<i>Interior Colors</i>			
	<i>Black</i>	<i>Light Beige</i>	<i>Light Gray</i>	<i>Torch Red</i>
<i>Competition Yellow</i>	<input type="checkbox"/>	<input type="checkbox"/>	<input type="checkbox"/>	
<i>Arctic White</i>	<input type="checkbox"/>	<input type="checkbox"/>	<input type="checkbox"/>	<input type="checkbox"/>
<i>Bright Azure Metallic</i>	<input type="checkbox"/>	<input type="checkbox"/>	<input type="checkbox"/>	
<i>Adrenaline Blue Metallic</i>	<input type="checkbox"/>	<input type="checkbox"/>	<input type="checkbox"/>	
<i>Dark Purple Metallic</i>	<input type="checkbox"/>	<input type="checkbox"/>	<input type="checkbox"/>	
<i>Torch Red</i>	<input type="checkbox"/>	<input type="checkbox"/>	<input type="checkbox"/>	<input type="checkbox"/>
<i>Dark Red Metallic</i>	<input type="checkbox"/>	<input type="checkbox"/>	<input type="checkbox"/>	
<i>Pale Green JT Metallic</i>	<input type="checkbox"/>	<input type="checkbox"/>	<input type="checkbox"/>	
<i>Black</i>	<input type="checkbox"/>	<input type="checkbox"/>	<input type="checkbox"/>	<input type="checkbox"/>

A Word About Engines

Chevrolet vehicles are equipped with engines produced by different operating units of GM, its subsidiaries or suppliers to GM worldwide.

A Word About Assembly

Chevrolet vehicles are assembled by different operating units of General Motors, its subsidiaries or suppliers to GM worldwide. Chevrolet vehicles incorporate thousands of components produced by different operating units of GM, its subsidiaries or suppliers to GM worldwide. We sometimes find it necessary to produce Chevrolet vehicles with different or differently sourced components than originally scheduled. All such components have been approved for use in Chevrolet vehicles and will provide the quality performance associated with the Chevrolet name. Since some options may be unavailable when your vehicle is assembled, we suggest that you verify that your vehicle includes the equipment you ordered or, if there are changes, that they are acceptable to you.

A Word About Updated Service Information

Chevrolet regularly sends its dealers useful service bulletins about Chevrolet products. Chevrolet monitors product performance in the field. We then prepare bulletins for servicing our products better. Now you can get these bulletins, too. Ask your dealer. To get ordering information, call toll free 1-800-551-4123.

Important:

A Word About This Catalog

We have tried to make this catalog as comprehensive and factual as possible. We reserve the right, however, to make changes at any time, without notice, in prices, colors, materials, equipment, specifications, models and availability. Since some information may have been updated since the time of printing, please check with your Chevrolet dealer for complete details.

GM Protection Plan

The available GM Protection Plan offers service protection in addition to that provided by GM's new-vehicle limited warranty. Ask your dealer about it. Coverage available only in the U.S. and Canada.

A Word About Air Bags

Always wear safety belts, even with air bags.

Turn Plastic Into Steel With The GM Card™.

The GM MasterCard®, with no annual fee, is the revolutionary financial vehicle specifically designed to help put you behind the wheel. Every time you use it, GM will credit 5% of your purchase toward buying or leasing the GM car or truck of your dreams. It could mean saving hundreds, even thousands of dollars, over and above any other discounts or rebates. Call 1-800-8GM-CARD for more information, including annual limits and restrictions.



SMARTLEASE® by GMAC makes it easy to enjoy the performance and luxury of Corvette. With SMARTLEASE, qualified customers can be approved in about one hour, and you enjoy low SMARTLEASE monthly payments. Plus, SMARTLEASE offers you choices at the end of your lease. You can either buy your Corvette at a price guaranteed up front, or return your vehicle with no other obligations — assuming the terms of the lease have been met. For more information about SMARTLEASE, or any of the other quality GMAC financing options, see your Chevrolet dealer or call

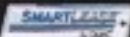

1-800-32-SMART.

Safety Features

Occupant Protection

- Supplemental Inflatable Restraint: manual lap/shoulder safety belts and air bags, driver/ passenger
- Energy-absorbing steering column
- Energy-absorbing instrument panel
- Interlocking door latches
- Folding front-seat locks, inertia-type
- Safety crossbars
- Breakaway inside rearview mirror
- Security door locks and door-retention components
- Laminated windshield glass, urethane-bonded
- Head restraints (integral)
- Side-door beams
- Passenger-guard inside door-lock handles
- Front and rear crash zones.



Accident Avoidance

- Side-marker lamps and reflectors
- Parking lamps
- Four-way hazard-warning flashers
- Backup lamps
- Directional signal control
- Windshield defrosters, washers and multi-speed wipers
- Inside day/night rearview mirror
- Outside rearview mirrors
- Brake system with dual master cylinder plus warning light
- Center high-mounted stop lamp
- Starter safety switch
- Low-glare finish (inside windshield moldings, wiper arms and blades, metallic steering-wheel surfaces)
- Illuminated heater and defroster controls
- Tires with built-in tread-wear indicators
- Audible disc brake lining-wear indicators
- Anti-lock brakes
- Traction Control
- Brake/transmission shift interlock (automatic transmission only).

Theft Deterrence

- Visible vehicle identification number
- Laser-etched VIN plate
- Theft-deterrent key locking system
- Theft-deterrent steering column lock
- PASS-Key II personal security system
- Remote inside hood release.

Genuine Customer Care

As a Corvette owner, you are covered by Genuine Customer Care, a comprehensive owner-protection plan that includes a 3-year/36,000-mile Bumper to Bumper Warranty with no deductible, Courtesy Transportation if your car needs warranty service, and a 24-Hour Roadside Assistance Program.

The Warranty

The GM 3-year/36,000-mile Bumper to Bumper Warranty covers repairs for all 1995 Corvettes, including labor and parts, to correct any defects in material or workmanship occurring during the warranty period. Warranty features include air conditioning repair, towing and no-cost warranty transfer. There is also emissions control system coverage, which varies by geographical location. Items not covered include tires (which are covered by their manufacturer) and normal maintenance. See your Chevrolet dealer for terms of this limited warranty.



The Assistance

For as long as you own your 1995 Corvette, the security and convenience of round-the-clock roadside assistance is available via a toll-free hot line (1-800-CHEV-USA). Your call will be answered by a Roadside Assistance phone advisor trained by Chevrolet. You will be placed in contact with a nearby service center, and assistance with towing, directions and many other helpful services will be arranged. See your participating dealer for more details.

In addition, the Corvette Action Center has a special toll-free number (1-800-457-VETT). It puts you in contact with Corvette experts who can handle any product/service question or problem you may have.



The Courtesy

Customers who purchase or lease a 1995 Corvette will be able to take advantage of Courtesy Transportation at no additional charge when their vehicles are left at a participating dealership for repairs covered under the 3-year/36,000-mile New Vehicle Limited Warranty. See your participating dealer for details.



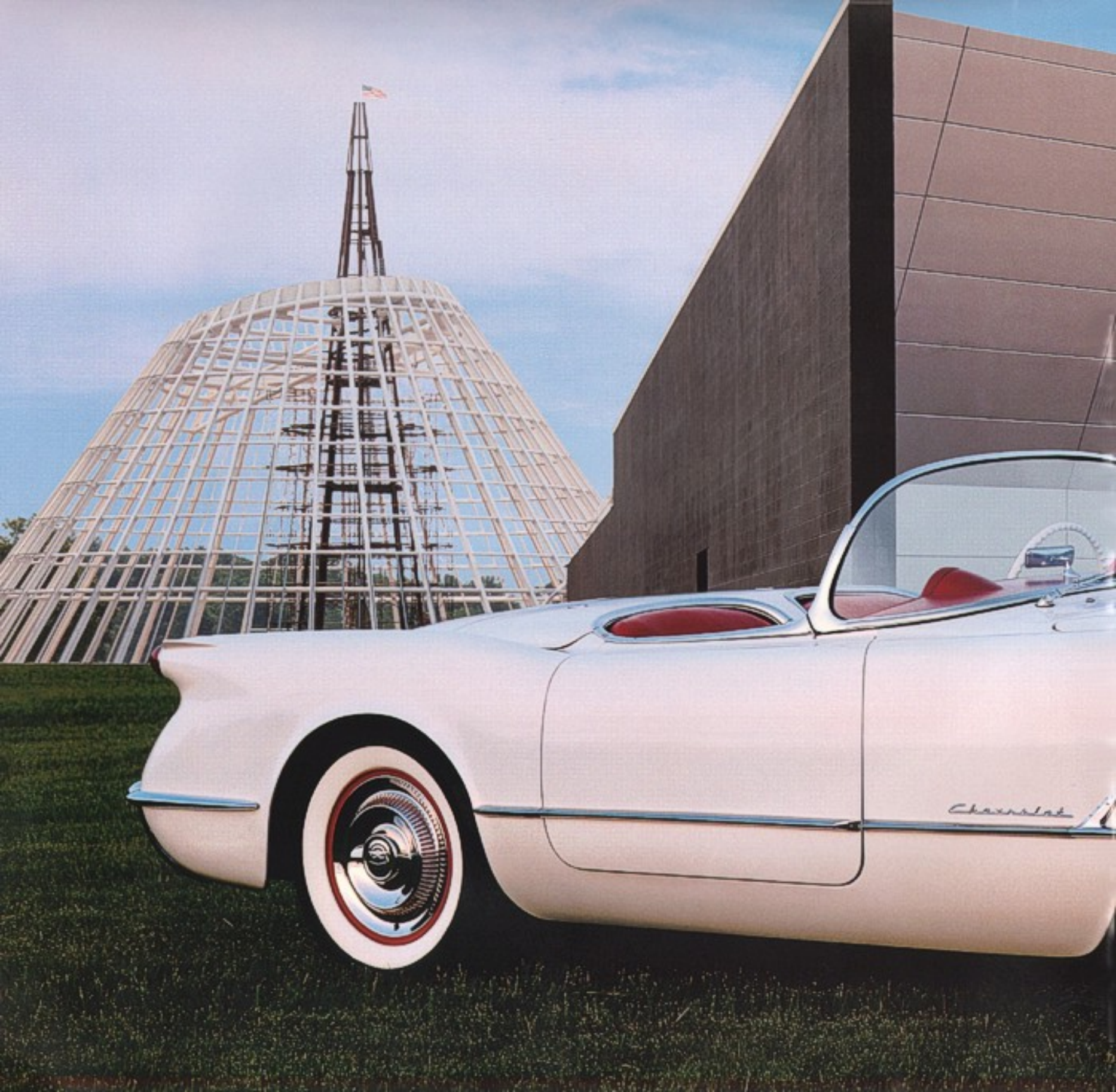



The '53 roadster

The Sting Ray Racer

The Make Shark

The one-millionth Corvette.

See them all at Corvette's hometown museum:

National Corvette Museum

P.O. Box 1953

Bowling Green, KY 42101

Phone: 502-781-7973.



Libro in 25€ - July 1994

General Motors, GM, the GM Emblem, Chevrolet, Buick, Oldsmobile, Cadillac, Pontiac, Opel, Saturn, Vauxhall, Chevy, Chevy II, and Chevy II Plus are registered trademarks and Chevy is a trademark of the General Motors Corporation. Suburban is a trademark of the GM Corp. GM, GMV, and FIVE-DOOR are registered trademarks of Delta Motorways. GMAC is a registered trademark of the General Motors Acceptance Corporation. ©1994 General Motors Corporation. All rights reserved.



GENUINE CHEVROLET

