

c o r v e t t e 82



If you're of a certain frame of reference, shall we say, you probably remember the way it was way back there in the mists of antiquity, twenty-nine years ago.

There was this American 2-seater. It had a top that

folded away clear out of sight, wire mesh headlight covers and a drive train featuring an overhead valve straight six, three 1-bbl. carbs and an automatic transmission.

It came in white, mostly, with red interior, and the Corvette engineering team decided to label it a sports

car. It sure didn't look like one of those things from Europe, though.

The buff book critics felt that maybe it was just too darn comfortable. They compared it with cars costing thousands more and assumed that it really didn't stand much of a

chance in the 24 Hours of Le Mans.

A year later, Chevy hired a Belgian engineer who shoehorned a small block V8 into the existing body and frame and then backed that with a 4-speed transmission.

You could have a lot of fun with one of those Corvettes, especially if the guy next to

you was driving a Jaguar XK120 Roadster or a 190SL Mercedes. And those cars, by golly, they *looked* European.

A few years later, along came a sleek apparition called a Stingray. A whole lot of amenities were provided. Windows winding up and down electrically, conditioned

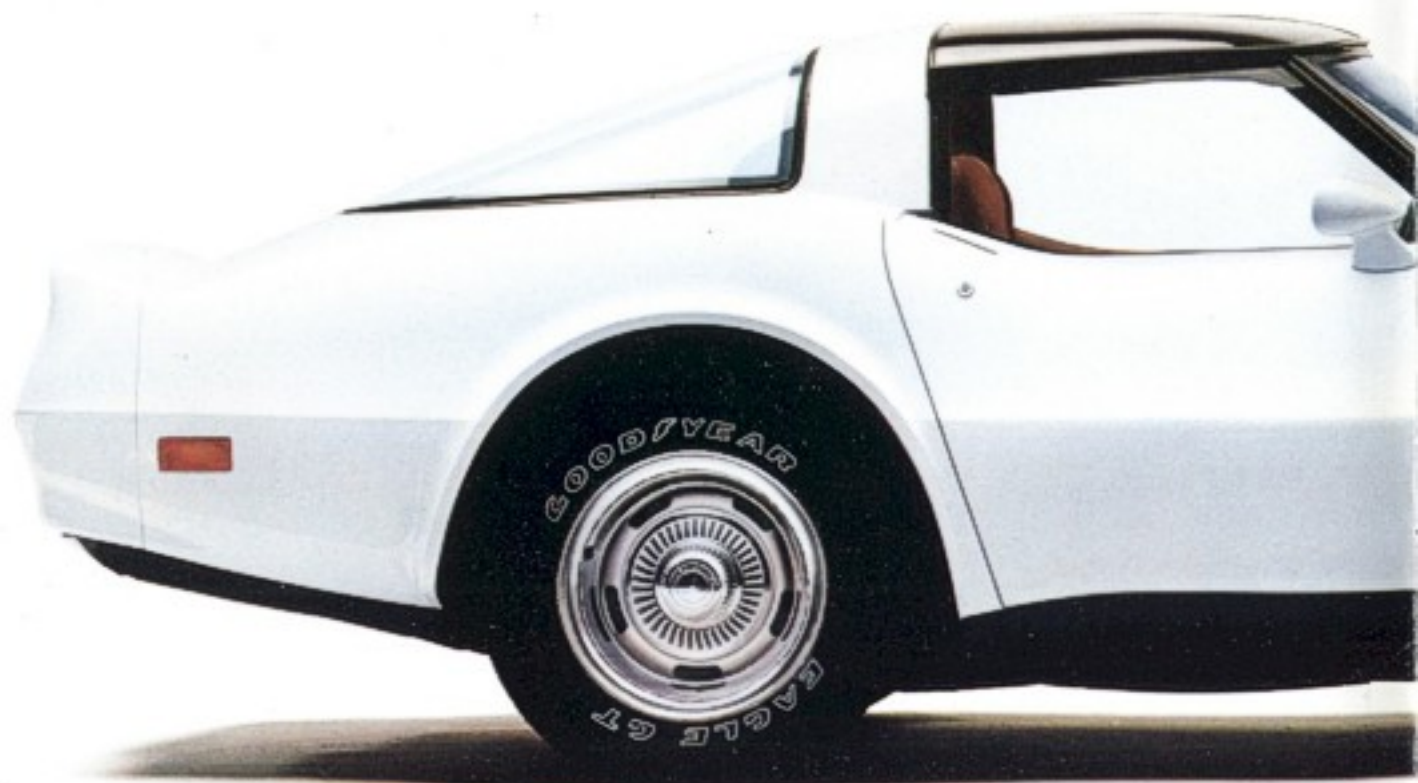



air, pop-off hardtop. There was even a coupe version.

And if that wasn't enough to cause quite a stir at the time, folks really took notice when a 427-cubic-inch engine was introduced for the Stingray along with a stiff suspension, a larger fuel tank and a few other tidbits.

Terrific, satisfying years.

Those Corvettes didn't look European at all and neither does the current model. It's an exciting kind of 'Vette that's coming on now. And sure the buffs still compare it with cars costing two to three times as much, only now European cars look like it. Almost.

**IMPORTANT: A WORD ABOUT THIS CATALOG.** We have tried to make this catalog as comprehensive and factual as possible and we hope you find it helpful. However, since the time of printing, some of the information you will find here

may have been updated. Also, some of the equipment shown or described throughout this catalog is available at extra cost. Your dealer has details and, before ordering, you should ask him

to bring you up to date. The right is reserved to make changes at any time, without notice, in prices, colors, materials, equipment, specifications and models. Check with your Chevrolet dealer for complete information.



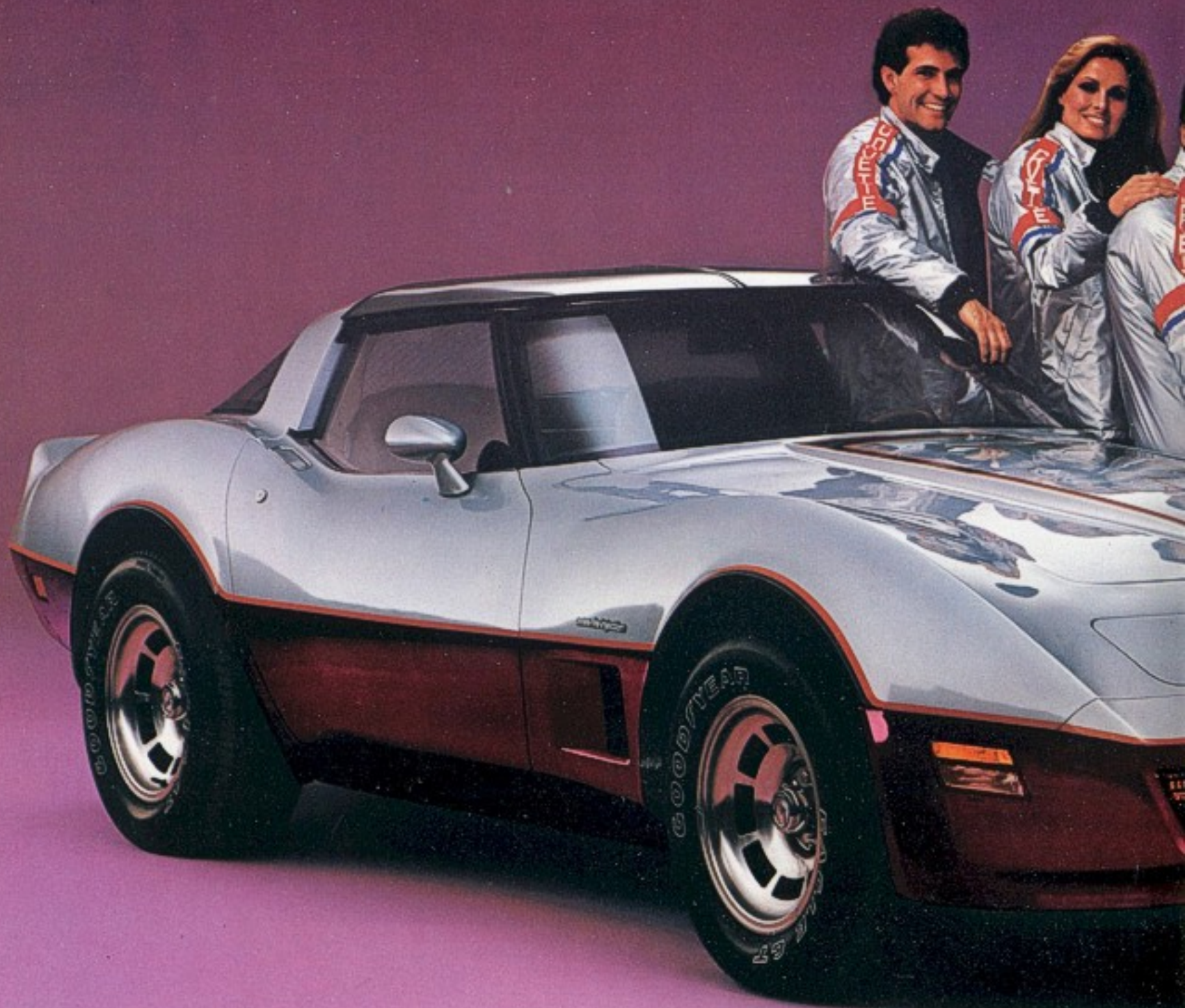



**THIS IS AN ENTHUSIAST'S  
KIND OF CORVETTE, A  
MOST CIVILIZED ONE.  
STILL IT'S A 'VETTE WITH  
THE SASSY-SOULED  
GUSTO OF ITS  
PREDECESSORS.**

This is still the road-wise sports car that's always been capable of inhaling great chunks of 2-lane tarmac and leaving you exhilarated even after a long ride. It's still the time and space machine enthusiasts aspire to.

There's a new civility now, however—predicated in large part on two engineering advances: Cross-Fire Injection and a 4-speed automatic transmission with overdrive fourth gear.

There's also a space age standard of fit and finish that is rigidly imposed and then carefully checked by inspectors at a new 1-million-square-foot plant in Bowling Green, Kentucky.

That's the beauty of Corvette ownership. Satisfying in creature comfort, yet precision-built to flatten the straightaways and glue down the corners.

Model depicted has optional leather-faced bucket seats. Two-Tone paint with pin striping is optional, as are Goodyear Eagle GT tires, aluminum wheels, and removable glass roof panels.



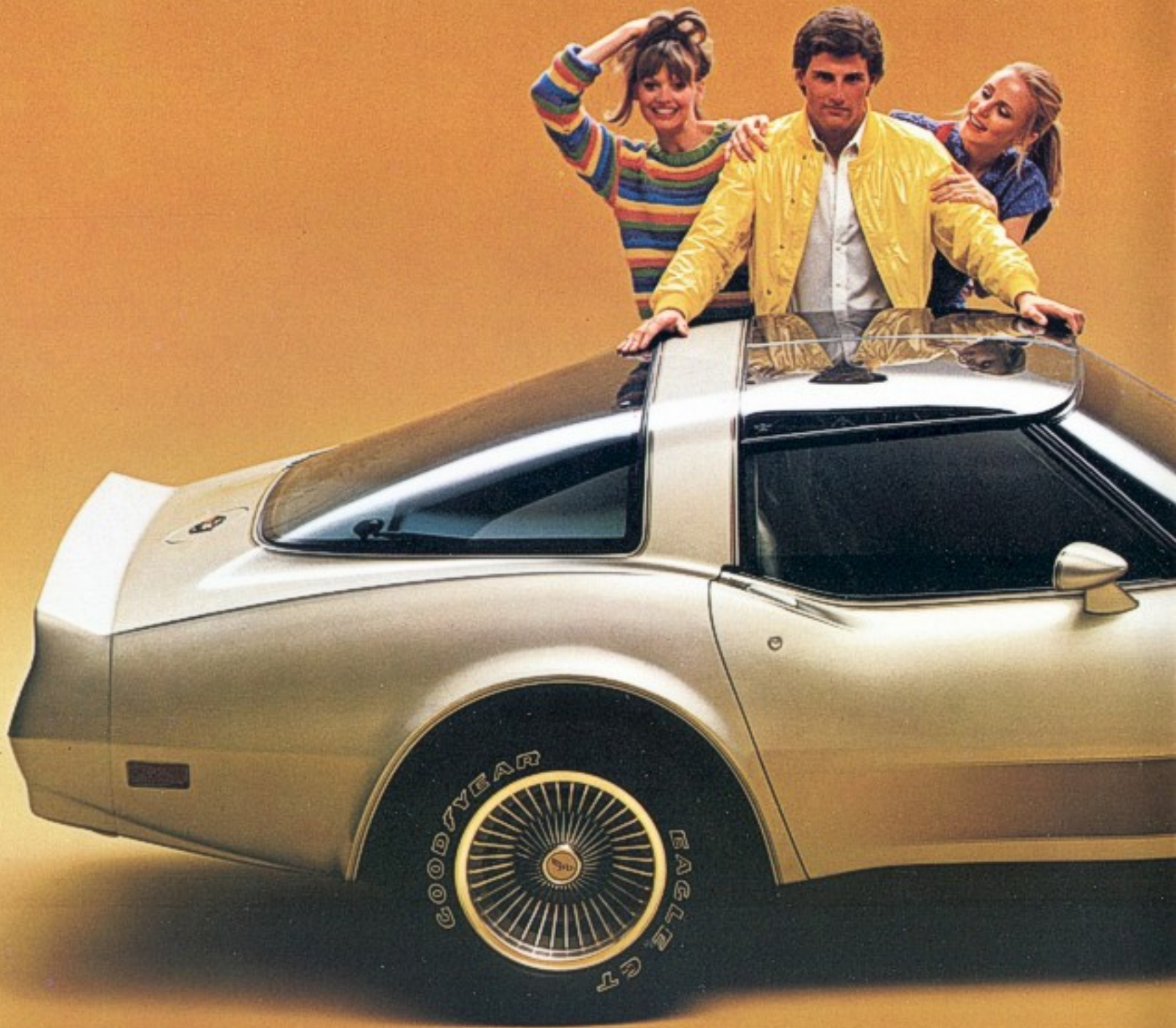



**THE  
"COLLECTOR  
EDITION." AN  
ADDED DILIGENCE  
OF DESIGN AND  
ADDITIONAL TIRE  
TECHNOLOGY.**

Unique silver-beige metallic paint, pin stripes and fading shadow treatment on the hood, fenders and doors distinguish the 1982 Collector Edition Corvette Hatchback Coupe.

From its distinctive cloisonné emblems to its specific wheels and hubs and on through its special Vehicle Identification Numbers (to help prevent someone from building a standard model into a Collector Edition), this is the Corvette to covet.

The Corvette engineering team established tough standards for the P255/60R-15 SBR tires, in terms of performance characteristics, and Goodyear responded with a set of raised,

white-lettered Eagle GT tires, standard only on the Collector Edition.

As another plus, removable glass roof panels with special bronze color and solar screening allow you to take full enjoyment from a sunny driving situation. Rear

window defogger and power antenna are standard.

The Collector Edition is a brilliant blend of sophisticated design and advanced engineering, a combination that promises the kind of roadability you've come to expect of Corvette and an unexcelled sense of style.









**A DISCIPLINED, ERGONOMIC ENVIRONMENT, BUT THERE'S A TANGIBLE LUXURY AND A HATCH THAT LIFTS TO THE AROMA OF FINE LEATHER.**

The Collector Edition interior—a driving environment that offers practical flourishes and considerate touches not always found in a 2-seater that is—frankly—still a rather spiffy hunk of road machinery.

And, now in the Collector Edition, a Corvette is available for the first time with a newly designed, fully lifting, frameless glass hatchback with remote release.

Inside? Matching silver-beige metallic interior with multi-tone leather seats and door trim. Standard, too, on the 1982 Collector Edition are the upgraded carpeting throughout and the theme-color, hand-sewn, leather-wrapped steering wheel that surrounds the leather-covered horn button which is surmounted by a cloisonné emblem. All this is framed by the deeply muted, dark beige console and instrument cluster trim plates.

That's what the 1982 Corvette Collector Edition is all about: an added dimension of interior and exterior refinements without sacrificing the more enjoyably reassuring aspects of driving one of the finest all-around 2-seaters in the world.

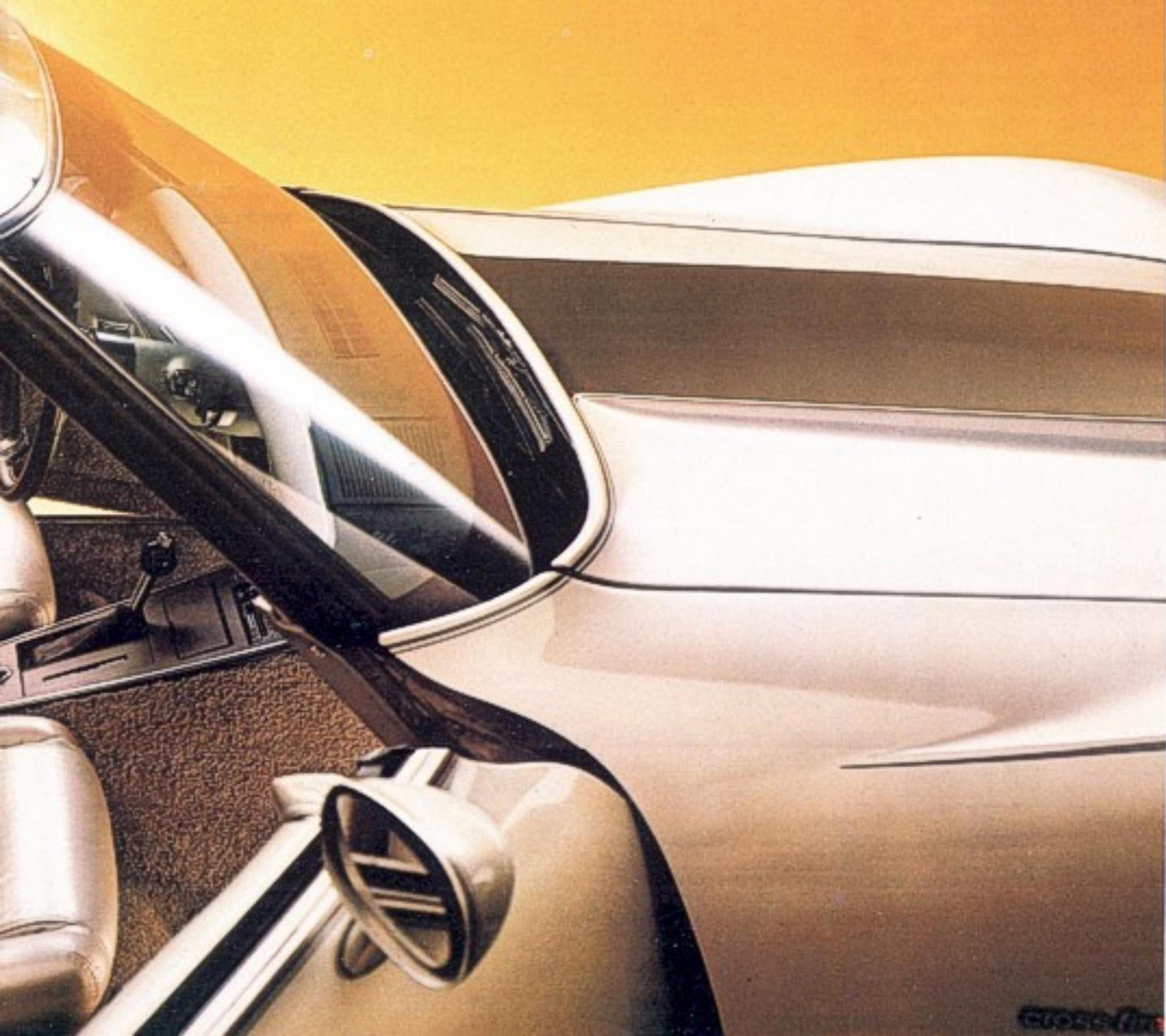

## CROSS-FIRE INJECTION

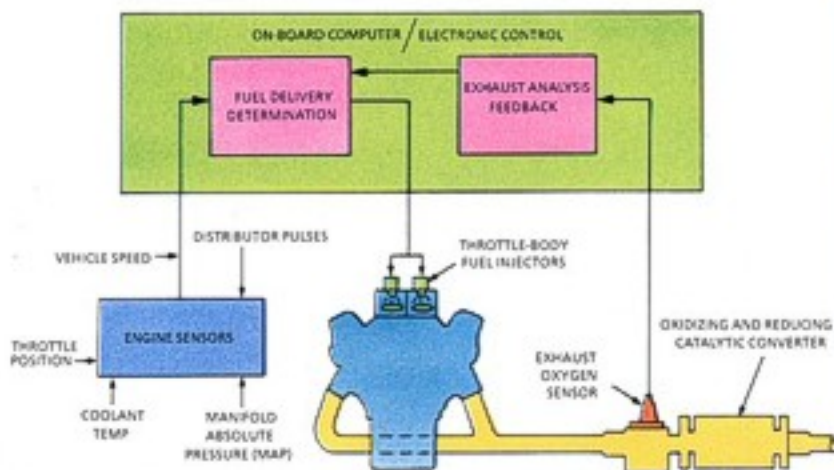

### CROSS-FIRE INJECTION ADDS TO THE CORVETTE PERFORMANCE EQUATION.

There's something new under the hood and it's called Cross-Fire Injection with dual throttle-body fuel injectors. It's not like any carburetor you know, and it's not like most fuel-injection systems around. What it is, is one of the most modern fuel-injection systems to date. As part of the entire Corvette drive train, Cross-Fire Injection adds to overall improved acceleration for 1982. And Corvette's compression ratio is an

impressive 9.0 to 1.

How it works: Cross-Fire Injection is a completely electronic system which constantly monitors and adjusts the engine air/fuel ratio to ambient driving demands. A pressurized fuel supply system incorporates an in-tank electric fuel pump with high-flow capacity and an 11-psi fuel pressure regulator integral with one of the throttle-body fuel injectors. Fuel is sprayed in a

## THROTTLE-BODY FUEL INJECTOR

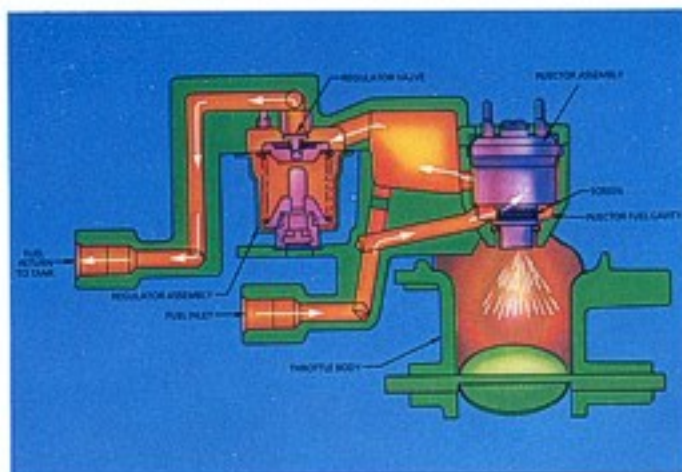

finely dispersed cone shape above the throttle blade in each of the dual-throttle bodies, resulting in improved mixture preparation. The amount of fuel required is calculated by the on-board electronic control module, based on engine sensor inputs of coolant temperature, manifold absolute pressure, engine speed and throttle blade positions, among others.

Simplified hardware eliminates mechanical choke, fuel metering components and idle speed controls and

their attendant adjustments. And electrical circuits are self-diagnostic for easy service.

Cross-Fire Injection is part of an interfacing component design, working with a low-back-pressure dual exhaust system, free-flowing monolith catalytic converter. In addition to the conventional snorkel, a new hood ducts outside air directly into the air cleaner during wide-open throttle operation through a solenoid-controlled door which opens on signal.

### CORVETTE POWER TEAM

Engine	Ordering Code	Displacement (cubic inches)	Engine Availability	Automatic Transmission
5.7 Liter Cross-Fire Injection V8 (A)	L83	350	Std.	Std.

Std.—Standard

(A) Produced by GM—Chevrolet Motor Division

### A WORD ABOUT ENGINES

Some Chevrolets are equipped with engines produced by other GM divisions, subsidiaries, or affiliated companies worldwide. See your dealer for details.

### AXLE RATIOS

With standard wheels	2.72
With aluminum wheels	2.87

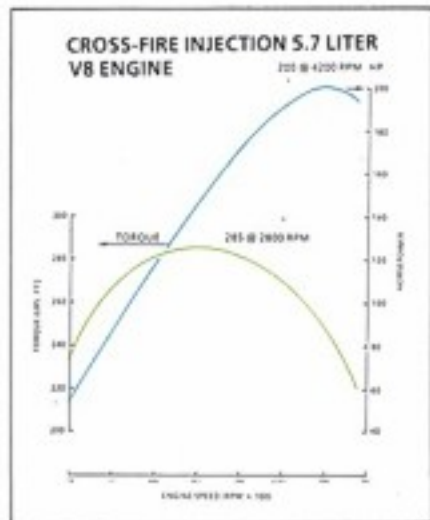
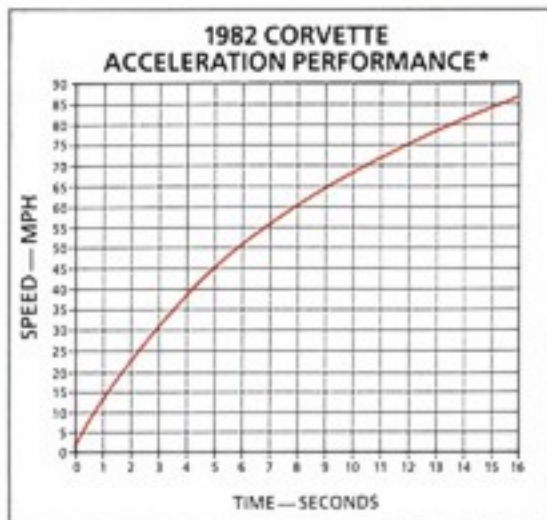

\*Tested with 2.72 rear axle ratio.

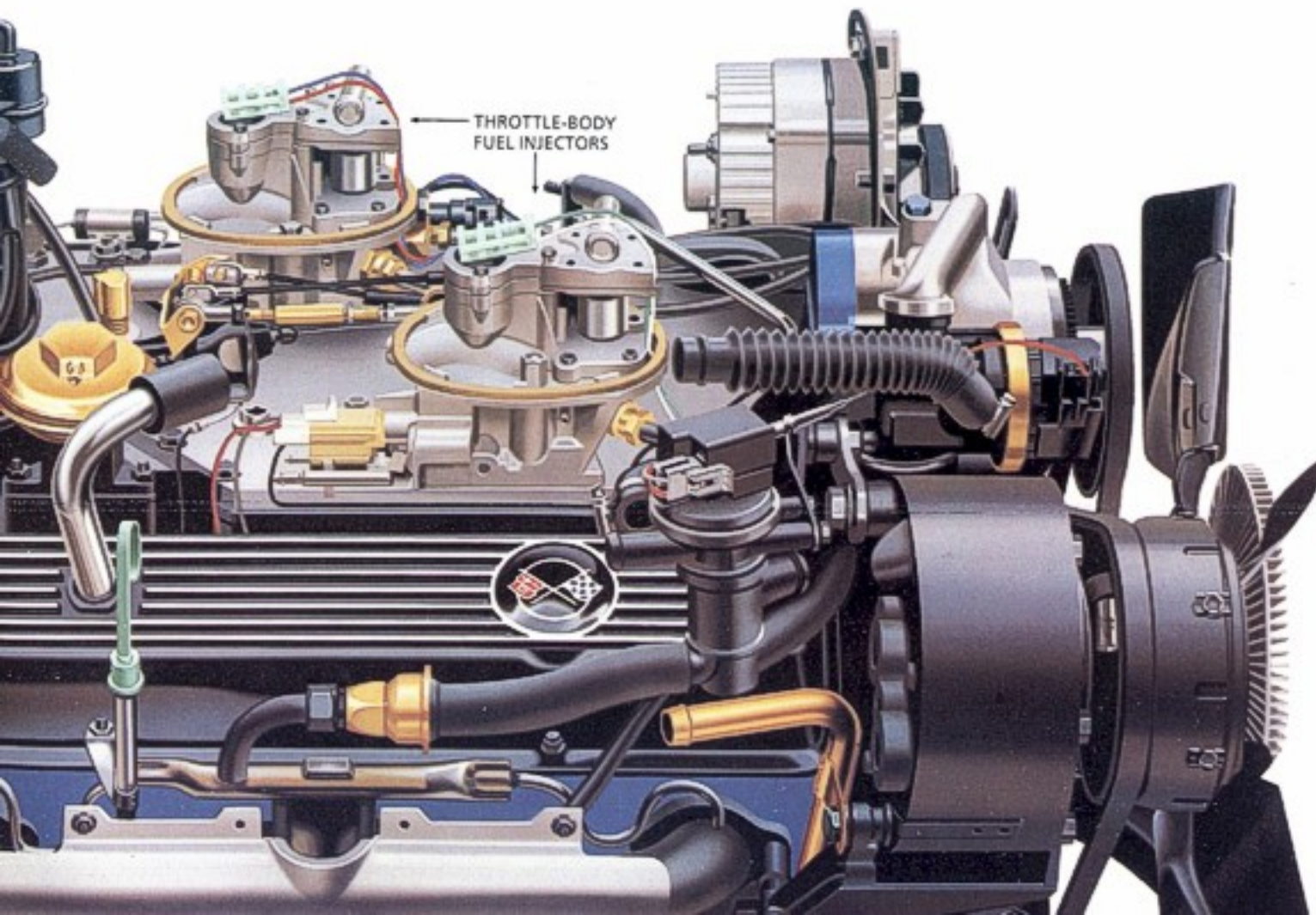



The world's first and only sophisticated filament-wound fiberglass-reinforced composite automotive spring now features new drive-shaft U-joint seals and splash shield for increased bearing life. U-joints are also larger and more durable. And this is still the lightest possible leaf spring application to be found in any automotive suspension. There is no interleaf friction. The spring supports the weight of the car that rests on the rear wheels and provides suspension compliance. Wheel position is controlled by a system of links and pivots.

#### 1982 CORVETTE BRAKE PERFORMANCE

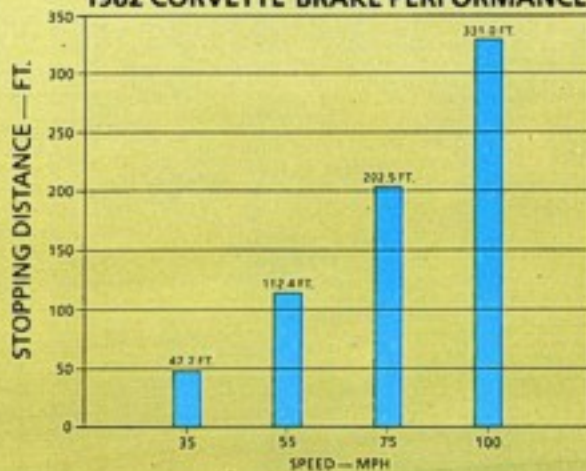

Corvette's 4-wheel self-adjusting disc brakes are virtually fade free. They provide impressive stopping power. High deceleration rates for sustained brake applications under severe operating conditions are possible.

#### Lateral Acceleration\*

Maximum lateral acceleration was measured on a 108-ft. radius circle with car equipped with standard suspension, standard Goodyear P225/70R-15 tires and 2.72 rear axle with the following results:

Max. Lateral Acceleration-G.

Left Turn	Right Turn	Average
.771	.739	.755

Car equipped with FE7 suspension, optimal Goodyear P255/60R-15 tires and 2.87 rear axle was measured on the 108-ft. radius circle at the following levels:

Max. Lateral Acceleration-G.

Left Turn	Right Turn	Average
.810	.769	.790

\*Based on acceleration tests at GM Proving Grounds.

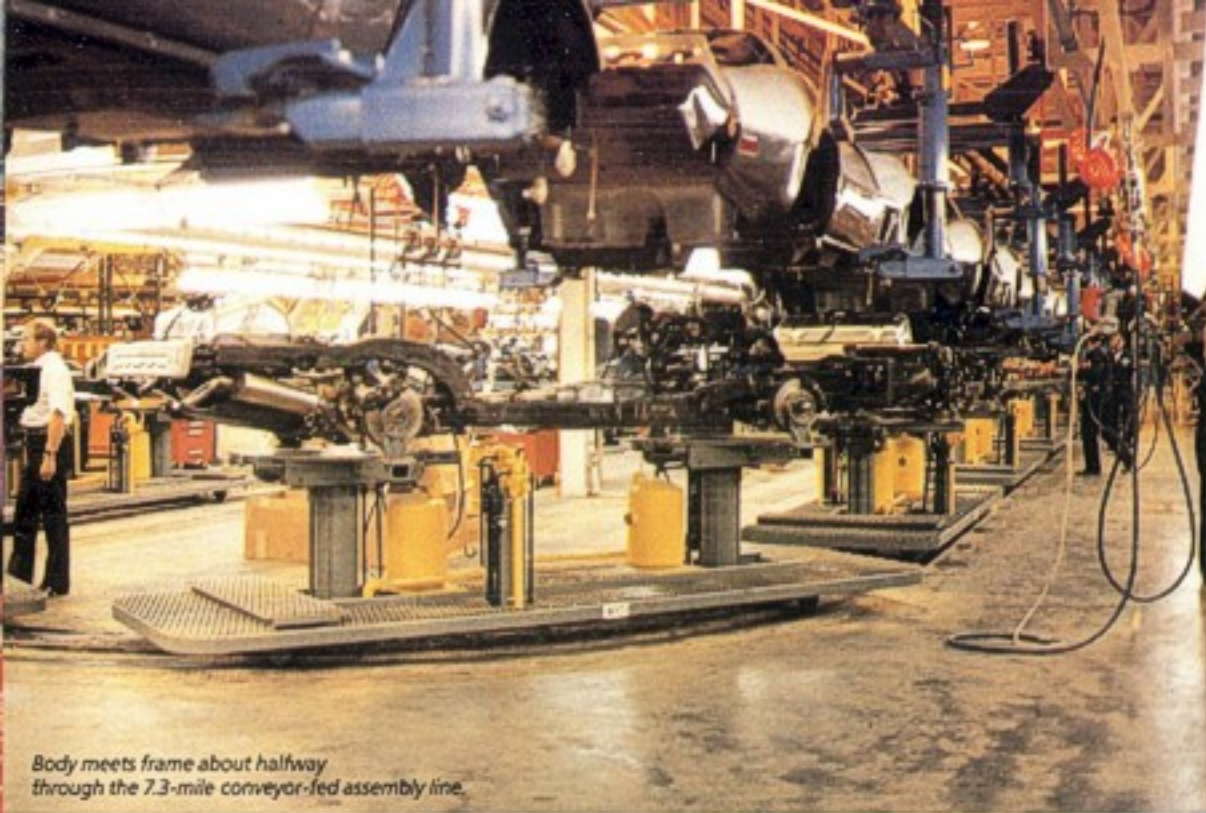

*Body meets frame about halfway through the 7.3-mile conveyor-fed assembly line.*

*Worker applies base coat in a virtually dust-free, special paint section of the line.*



*After a final clear coat, the finish is hand-polished and imperfections noted and removed.*



*The first of six coats of color is applied to the body by spray gun specialists.*



*Inspectors rigidly enforce the quality of the paint.*



**THE NEW BOWLING GREEN PLANT IS THE NEWEST SPORTS CAR PRODUCTION FACILITY IN THE WORLD. THE RESULT IS A COMBINATION OF MODERN TECHNOLOGY AND QUALITY WORKMANSHIP.**

Product pride. That's the operating philosophy of the new million-square-foot assembly plant in Bowling Green, Kentucky. And it shows in the new Corvettes now rolling off the lines. They represent the culmination of what we've learned about building America's favorite 2-seater over the years—as well as state-of-the-art manufacturing science of the new plant.

Attention to detail assures smooth operation of the plant. The dispatch room contains electronic sensors that measure operation of most of the systems. Inspection centers are built into the assembly flow throughout the plant—so the end product is a Corvette we can be proud of.

New technology is put to the test here. One dream that has become reality is a paint system that applies a clear coat over a larger-flake metallic base. Paint technicians are specially clothed, working in a sealed environment, to help guard against airborne particulates. The resultant paint finish usually scores a dazzling 95% on the "glossmeter." Not bad, considering a mirror registers 100%.

Pride is everywhere. The plant. The people. The product. A "quality first" philosophy means a first-quality Corvette for you.



*Corvettes awaiting shipment to Chevrolet dealers.*



*Chevy makes good things happen... for you*

**Chevrolet**