

'74 CORVETTE

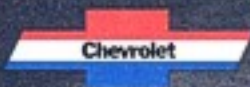

BUILDING A BETTER WAY TO SEE THE U.S.A.



Chevrolet

IF YOU ARE CONSIDERING YOUR FIRST CORVETTE...

We know what you feel.

We know what it's like to possess (and be possessed by) a car so exciting to look at that it makes the scene wherever it stops. Or turns heads wherever it goes.

And we know the feeling of a friendly wave of the hand (or flick of the lights) when you meet another Corvette on the road... of being a part of a whole new and exciting life style.

We *know* because we've been there.

But there's more. You can't really appreciate a Corvette

until you look past the image to the car, itself. So, for the next few pages, we'd like to show you what's behind this dramatically styled car that captivates owners and onlookers alike. To what's outside, inside and underneath that makes Corvette the sought-after sports car it's been for over 20 years.

It's a great trip. Getting to know a Corvette has got to be one of the great pleasures in life.

And anyone who truly loves the road and where it goes deserves that pleasure at least once in his life. Or hers.



IF YOU HAVE ALREADY OWNED A CORVETTE...

Who knows better than you that the basic Corvette formula is too good to mess with. Right?

Relax! The same people who brought you *your* Corvette are still running the store and keeping the faith. The '74 isn't a totally new Corvette, just better.

Take the styling. We wouldn't just change it for the sake of change. But when we made the rear bumper stronger, we made Corvette's entire rear styling look different. And, we think, better. (You can see it beautifully on page 4.)

Take another example. Remember last year? When we tuned the body and chassis for steel belted radials? It made the interior quieter. Quiet enough that the exhaust sounds, which had been a pleasant part of the background, seemed to be too prominent.

So, this year, we did some more tuning—in the dual exhaust system. We added a pair of resonators . . . mini-mufflers. *Voilà!* The '74 Corvette still delivers the growl of performance you know and like, but at a level that now lets you enjoy Corvette's available FM stereo radio to its hilt.

So be reassured. The 1974 Corvette still represents what it set out to be: A car that combines the road-holding and handling qualities of a true sports car with the grace and refinement of a personal luxury car. After all, that's why Corvette is so much in demand. And who would want to change that? Not us. Not you.



Many Options and Custom Features are available for Corvette. Some are illustrated or described in this catalog.

STANDARDS

THE BODY

We're not about to take all the credit for the exciting shape of Corvette's body. Basically, what we set out to do was design a fiberglass envelope that would house two passengers, one engine and four independently suspended wide-base wheels. All designed to minimize aerodynamic drag.

By the time we finished our wind-tunnel testing, we had it all. We also had a big bonus: One of the greatest looking shapes on any road. Which proves that virtue is rewarded.

However, we will take full credit for making sure those aerodynamic lines are wrapped around a rugged steel cage. Including side-guard beams in the doors. And protected from minor impacts by improved bumpers, front and rear, concealed under resilient body-color urethane fairings. This should add peace of mind when you leave your Corvette parked at the curb.

And we'll also take credit for all those other Corvette touches. Like power-retractable dual headlights. Soft-Ray tinted glass. An air scoop in the hood that hypox top-end engine performance. Even an anti-theft audio alarm system, controlled from a convenient lock in the left front fender.

For the coupe, we came up with a classic . . . those remove-and-store-inside roof panels that let you convert from closed car to open car in a matter of seconds. For the convertible? A fast-folding top (black or white) that completely hides away under a flush panel in the rear deck.

And that's just the body!

THE CHASSIS

When talk gets going among serious sports car buffs, the importance of independent rear suspension usually comes up. The idea behind it is simple: Help keep your rear wheels on the road by cutting down weight that has to go up and down with the wheels.

In Corvette we take weight out of the rear suspension by mounting the differential on the frame. With no massive differential to inhibit the action, the wheels are free to follow the contours of the road more closely. Which gives Corvette the kind of road-holding and traction you expect of a great sports car.

To boost traction more, Corvette's equipped with a Posi-traction differential. It goes to work when either rear wheel starts to spin . . . automatically limiting torque to that wheel until it gets a hold on the road, again. Great on wet or slippery pavements.

As for tires, Corvette lays four big footprints on the road with wide GR70-15 steel belted radials (more hold, more traction). And there's a ventilated and self-adjusting disc brake at *each* wheel.

To make everything go, Corvette's standard power team gives you a responsive 4-barrel 350-cube V8, coupled to a fully synchronized 4-Speed manual transmission. Of course, there are other outstanding power teams available, too. (See page 6 and back cover.)

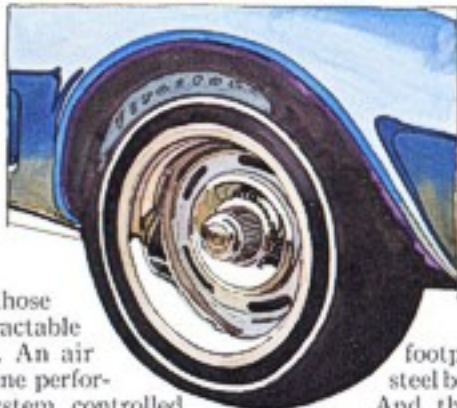

'74 Corvette Stingray Convertible.



'74 Corvette standard all-vinyl interior.

THE INTERIOR

If the outside of Corvette is exciting, the inside is fabulous. There are warm courtesy lights when you open either door. Lavish color-keyed deep-twist carpeting. Rich textured vinyl seat trim. And the seats themselves . . . deep-pleated and saddle-stitched for that special Corvette look and feeling . . . with deep foam for comfort . . . contoured for the support you want on long trips. They're even canted at the edges to keep you firmly positioned behind the wheel, during hard cornering.

Tipping either seat back forward gives you access to the carpeted and surprisingly roomy luggage space. Two under-the-floor compartments (one lighted and lockable) provide concealed storage for cameras and other valuables. A third gives access to the battery.

Two people, going anywhere, never had it so good.

INSTRUMENTS & CONTROLS

The real soul of the Corvette interior comes on when you start up and settle back.

Everything you want to see is right in view. Tachometer and speedometer-trip odometer are over the steering column, big and prominent. Your auxiliary instruments (fuel, temperature, sweep-second-hand clock, oil pressure and ammeter, plus seat belt, door ajar and headlight door warning lights) are just to the right, over the console. This year, we also widened the rearview mirror to a full 10 inches to give you a broader view astern.

Corvette controls are practically an extension of your arms and legs. The sports-type wheel is well forward for superb steering control. The center console puts the shift selector right under your palm (with the hand brake directly behind). Heater-ventilation controls, lighter and ashtray are right at your fingertips. Even the brake and accelerator are positioned so you can do a crisp and credible heel-and-toe downshift.

You might say your Corvette interior is as personal and as practical as a pair of driving gloves.

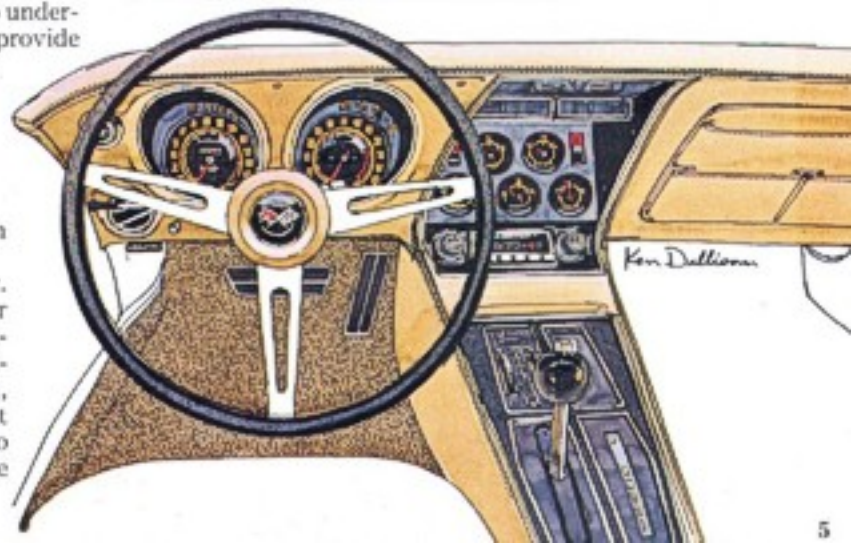

OPTIONS

FOR THE BODY



Removable Hardtop (for convertible)—The way to give your convertible top a vacation during cold weather. And yourself the added warmth and quiet of a hardtop. It's styled to

enhance the lines of the Corvette and can be ordered to match the exterior color, or with an available black vinyl roof cover for a more formal look.

Luggage Rack (dealer-installed)—It's handsome enough to be strictly a dress-up item. But isn't it nice that it also lets you store the occasional overflow from your luggage compartment?

Also Available (from your dealer)— • Right-hand outside mirror • Non-vented locking gas cap.



FOR THE CHASSIS

Turbo-Fire 350-4 Special V8—When we say that we've given this 350 a special carb, cam, crank, cylinder heads, pistons, rods, even finned aluminum rocker arm covers, we still haven't said it all. Designed to come on in the higher RPM numbers, the Special is obviously an engine for the enthusiast.

Turbo-Jet 454-4 V8—Like they say: "Nothing beats inches." And with 454 cubic inches of displacement, the Turbo-Jet provides a lusty torque output over the entire RPM operating range. This engine, like all 1974 Corvette engines,

features a new multi-louvered radiator for improved cooling in city traffic conditions.

Console-Shift Turbo Hydra-matic Transmission—Think of this automatic three-speed as a box with a dual personality. Leave it in "Drive" range when you've got other things on your mind. Shift it manually with the console T-handle when special acceleration or engine braking needs are called for. Available with all engines.

Close-Ratio 4-Speed Manual Transmission—Fully synchronized with a 2.20:1 first gear ratio, this gearbox provides

less overall ratio but more closely spaced gear ratio increments than the standard box so you can stay closer to where the power peaks. Available only with Turbo-Fire Special or Turbo-Jet engines.

Gymkhana Suspension—Here's a sporty package for the enthusiast (not recommended for general use). Provides higher rate springs, front and rear, for a firmer ride. Plus a larger diameter front stabilizer bar to minimize lean.

Also Available— • Off-Road suspension package (includes the Gymkhana suspension described above, plus heavy-duty power disc brakes, front and rear)

- Power steering, with fast steering ratio for quick response
- Power brakes (there's nothing unpure about a power assist)
- Heavy-duty battery (standard with Turbo-Jet engine).
- White stripe or white lettered GR70-15 steel belted radial tires.

FOR THE INTERIOR

Radios—You haven't heard anything yet until you've heard FM stereo in a Corvette. It's an unbelievably great sound you don't want to miss.

Try it, or the FM monaural radio. Both have AM band, dual speakers, solid-state circuitry, fixed-height antenna and ignition shielding.

Custom Interior Leather Trim—Frankly, gorgeous. But, then, it takes a lot to top Corvette's standard interior. In addition to the unmistakable texture and scent of leather in the seating areas, this interior brings you the added luxury of

harmonizing deep cut-pile nylon carpeting and wood-grain vinyl inserts on the doors and console.

Air Conditioning—Cools, heats, dehumidifies, does it all. Because Four-Season air conditioning is factory-installed as an integral part of Corvette's ventilation-heating system with all controls consolidated on the console. And now, there's an additional cooler outlet on the driver's side that improves the air circulation over our '73 design. Which makes Four-Season air conditioning more desirable than ever.

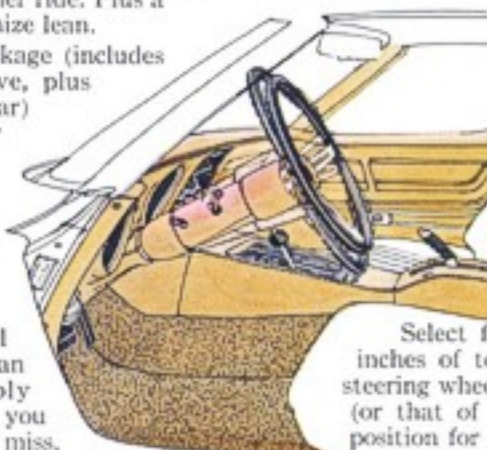

Tilt-Telescopic Steering Wheel—

Select from seven tilt positions, and six inches of telescope travel, and you put the steering wheel exactly where it suits your style (or that of another driver). Vary the wheel position for a relaxing change of pace on long trips. Tilt it up for easy entry and exit. Many

owners classify Corvette's Tilt-Telescopic steering wheel as a desirable necessity.

Also Available— • Power windows (with convenient console switches) • Rear window defogger • New rearview mirror-mounted map light.

Available (from your dealer)— • Compass • Infant safety carrier, child safety seat (GM Love Seats) • Hand spotlight • 23-channel Citizens' Band two-way radio • Fire extinguisher.



'74 Corvette Custom Interior with leather seat panels.

The items described here are available at extra cost for '74 Corvettes. Your Chevrolet dealer can answer any questions about specific details.

SPECS.

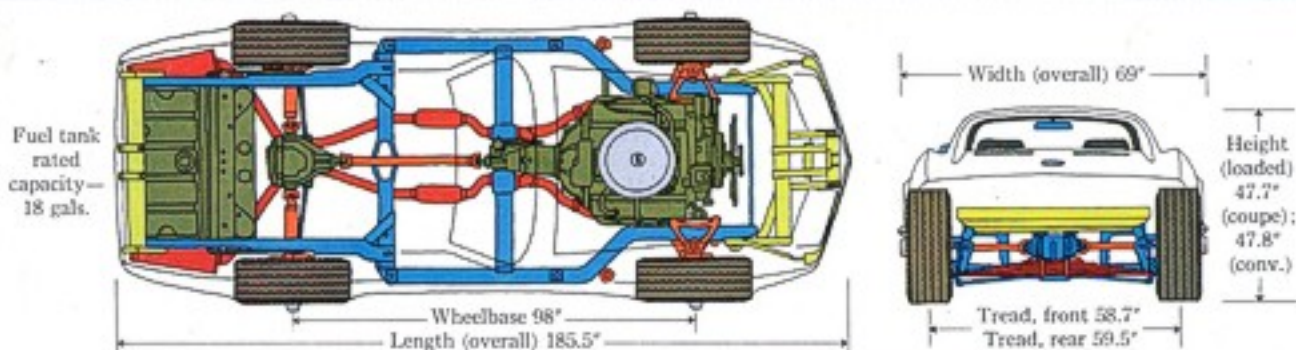

EXTERIOR COLORS

Corvette Dark Green Metallic (New)
 Corvette Gray Metallic (New)
 Corvette Brown Metallic (New)
 Corvette Bright Yellow (New)
 Corvette Medium Red Metallic (New)
 Corvette Silver Mist
 Corvette Medium Blue Metallic
 Mille Miglia Red
 Corvette Orange Metallic
 Classic White

INTERIOR TRIM COLORS

All-Vinyl (Standard)

- Silver (New) • Light Neutral (New)
- Medium Saddle • Dark Blue
- Dark Red • Black

Custom Interior (Available)

- Silver (New) • Medium Saddle (New)
- Black

SAFETY AND SECURITY FEATURES

Occupant Protection. Two combination seat and shoulder belts (convertible, seat belts only) with pushbutton buckles for driver and passenger with reminder light and buzzer, starter interlock and (coupe only) shoulder belt inertia reels. Built-in head restraints. Safety steering wheel. Energy-absorbing steering column. Energy-absorbing padded instrument panel. Padded sun visors. Passenger-Guard door locks. Side-Guard beams. Safety door latches and hinges. Safety armrests. Folding seat back latches. Contoured windshield header (except convertible). Thick-laminate windshield.

POWER TEAMS

ENGINE	TRANSMISSION	POSITIONAL AXLE RATIO Without Air Conditioning		POSITIONAL AXLE RATIO With Air Conditioning	
		Std.	Avail.	Std.	Avail.
STANDARD ENGINE 195 hp @ 4400 RPM* Turbo-Fire 350-4 V8	Std. 4-Speed (2.52:1 low)	3.36	3.08	3.36	3.08
	Turbo Hydra-matic	3.08	3.36	3.08	3.36
AVAILABLE ENGINES 250 hp @ 5200 RPM* Turbo-Fire Special 350-4 V8 (RPO L82)	4-Speed (2.52:1 low)	3.55	3.70	3.55	—
	4-Speed (2.20:1 low)	3.70†	3.55	3.55	—
	Turbo Hydra-matic	3.55	3.70	3.55	—
270 hp @ 4400 RPM* Turbo-Jet 454-4 V8 (RPO LS4)	4-Speed (2.52:1 low)	3.08	3.36	3.08	—
	4-Speed (2.20:1 low)	3.36**	3.08	3.36	—
	Turbo Hydra-matic	3.08	3.36	3.08	—

*Net horsepower rating, in accordance with Society of Automotive Engineers standards, represents the power output of engine as installed in automobiles.

†Ratios available with Off-Road suspension (RPO Z07): 4.11, 3.70, 3.55 or 3.36.

**Ratios available with Off-Road suspension (RPO Z07): 3.55, 3.36, or 3.08.

Note: California Emission Equipment (RPO YF5) required on all Corvette engines in California.

All 1974 Corvette engines are equipped with advanced exhaust emission control systems, and are designed to operate efficiently on unleaded or low-lead fuels of at least 91 Research Octane. In addition to the lower exhaust emissions attainable, there are benefits in longer life for your spark plugs, exhaust system and other engine components. If these unleaded, low-lead gasolines are not available, any leaded 91 Research Octane or higher regular grade fuel containing 0.5 grams, or less, of lead per gallon should be used.

Accident Prevention. Side marker lights and reflectors (front side marker lights flash with direction signal). Parking lights that illuminate with headlights. Four-way hazard warning flasher. Backup lights. Lane-change feature in direction signal control. Windshield defroster, washers and dual-speed wipers. Wide-view inside day-night mirror (vinyl-

edged, shatter-resistant glass and deflecting support). Outside rearview mirror. Dual master cylinder brake system with warning light. Starter safety switch. Improved bumper system.

Anti-Theft. Anti-theft ignition key warning buzzer. Anti-theft steering column lock. Anti-theft audio alarm system. Inside hood latch release.

Chevrolet

All illustrations and specifications contained in this literature are based on the latest product information available at the time of publication approval. The right is reserved to make changes at any time without notice in prices, colors, materials, equipment, specifications and models, and to discontinue models. Chevrolet Motor Division, General Motors Corporation, Detroit, Michigan 48202. Litho in U.S.A.

GM

MARK OF EXCELLENCE