





PURE **DRIVING** PASSION





I. ABOUT FISKER

09
The Fisker
Manufacturing Story

10
Principles of Design
· Philosophy
· Inspiration

11
Sustainability
· Environmental
Commitment

13
Plug-in Hybrid
· PHEV Technology
· Performance

14
Vision

II. ABOUT KARMA

15
Performance
· Stealth Mode
· Sport Mode

17
Drivetrain
· Transmission
· Q-Drive
· Battery

18
Technology
· Command Center
· Keyless Start

20
Design Interior
· Wood
· Leather
· Premium Eco-Suede

24
Design Exterior
· Solar Roof
· Diamond Dust Paint

26
Audio
· Interior Sound
· Exterior Sound

27
Safety
· Aluminum Frame
· Brakes
· Air Bags
· Safety Ratings

28
Specifications

III. CONFIGURATIONS

34
Exterior
· Colors

35
Interior
· Colors
· Woods

36
Options
· EcoChic
· EcoSport
· EcoStandard

37
Letter of Authenticity

38
Warranty and Service

IV. COMPANY INFO

39
Contact Information

V. LEGAL

40
Legal





The harmonious balance of nature was the inspiration that drove us to design one of the most sustainable and accountable vehicles in automotive history.

Developed to the exacting standards of Henrik Fisker, visionary automotive designer of the Aston Martin DB9 and the BMW Z8, the revolutionary Fisker

Karma surpasses the expectations of the most discerning automotive experts. With strikingly original designs that capture the dynamic forces of nature, the

Fisker Karma truly is the world's first premium plug-in hybrid electric vehicle.



THE FISKER MANUFACTURING STORY

Henrik Fisker and Bernhard Koeehler share over 51 years of combined experience in the automotive world. They joined forces as Fisker Coachbuild in 2005, a venture which saw the team reviving the lost art of coachbuilding, designing custom automobiles to customer specifications.

The duo led teams that utilized powertrains and chassis from other luxury European Manufacturers until 2007 when they founded Fisker Automotive, a true automobile manufacturer which introduced the world's first premium plug-in hybrid electric vehicle, the Fisker Karma.

**PRINCIPLES
OF DESIGN**

PHILOSOPHY

Our design philosophy emphasizes that unrivaled purity translates to every element of the Fisker.

INSPIRATION

We drew inspiration from nature's harmonious balance in every element of the car's design for a pure, clean styling that celebrates timeless beauty.





SUSTAINABILITY

ENVIRONMENTAL COMMITMENT

For sourcing environmentally conscious and sustainable materials, if we felt the existing technologies didn't meet our uncompromising standards, we developed new, superior approaches. Our unwavering commitment to purity throughout the Fisker Karma reflects our dedication to introducing accountability to luxurious automotive design.



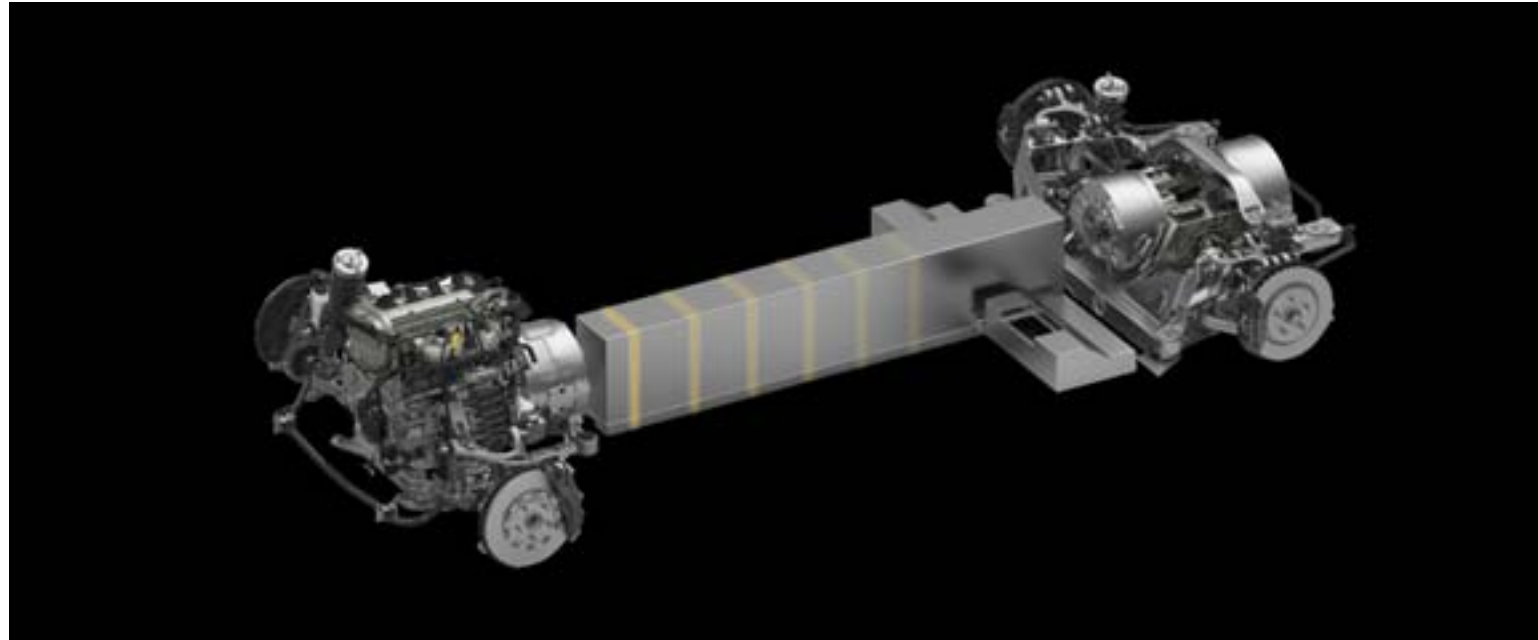

PLUG-IN HYBRID

PHEV TECHNOLOGY

Plug-in Hybrid Electric technology is a unique system comprised of 2 electric motors, 1 Lithium-ion battery, and 1 internal combustion engine.

PERFORMANCE

Lithium-ion battery charge capacity permits up to 50 miles of electric driving. After 50 miles, the internal combustion engine engages to support the electric motors. (note: the plug-in hybrid is never run by the engine. The engine provides the energy to run the electric motors.)



PERFORMANCE

STEALTH MODE

All-Electric Stealth Mode exclusively powers the Karma with a Lithium-ion battery.

- Top Speed 95 mph (153 km/h)
- 0-60mph in 7.9 seconds
- Total Range of 50 Miles

SPORT MODE

Sport Mode combines the power of a Lithium-ion battery and an internal combustion engine.

- Top Speed 125 mph (200km/h)
- 0-60mph in 5.9 seconds
- Total Range of 250 Miles



NW

73
mph

22°

SPORT





DRIVETRAIN

TRANSMISSION

Single Speed Fixed Gear

Q-DRIVE

Developed by Quantum Technologies exclusively for Fisker Automotive.

Karma's Q DRIVE configuration consists of an internal combustion engine working in series with a generator and a Lithium-ion battery pack to power the electric motor that turns the rear wheels.

BATTERY

Details

The Fisker Karma utilizes a 20 kW/h (200kW peak) Lithium-ion battery with an extremely stable Iron Phosphate composition.

Charging Stations

Fisker's high-voltage charging station can easily be installed in homes with standard electrical service.

Charge Times

Varies with battery's remaining charge capacity and whether 110v, 220v or 240v current is used. Between 6 hours and 14 hours.

Battery Lifecycle

Battery maintenance is minimal with a 10 year or 100,000 mile lifecycle.

Cost

Cost is equivalent to \$0.71/gallon. As little as \$0.03/mile (€0.02/km) in electric-only 'Stealth' mode, based on SAE calculations. A real world annual average (67% electric only) is closer to \$0.07/mile (€0.05/km).

Cost Savings

Varies with driving habits. Average estimate of \$1,500 per year versus similarly-sized, V8-powered luxury car.



TECHNOLOGY

COMMAND CENTER

Intuitive touch-screen interface controls the Karma's audio, phone, climate, navigation, infotainment, and additional systems.

- Task specific visuals
- Haptic feedback touch/gesture responses
- Vibrant 10.2" touch-screen
- Contextual application displays
- Environmental visualization options relative to Date/Time/Location
- Quick, intuitive transitions between tasks/modes
- Variable engagement modes accommodate user skill levels



KEYLESS START

Instantly activate your Karma with the remote proximity start system.



DESIGN

INTERIOR

Wood

Rescued Wood: Certified rescued wood retrieved from the 2007 firestorm in Orange County, CA.

Sunken Wood: Certified sunken wood sourced from the bottom of Lake Michigan.

Fallen Wood: Certified fallen wood from California storms.





Premium Eco-Suede

- 100% Recycled post-industry virgin polyester Ultrasuede® reduces energy consumption and CO2 emissions by 80% during the recycling process.
- Ultrasuede® EcoDesign™ products deliver on the promise of excellence through environmental responsibility, inherently beautiful design, and flawless engineering.

Leather

- Treated at the world's first energy self sufficient, closed-loop leather manufacturing plant with both gas and electricity generated on-site from by-products of the leather making process.
- Low Pigmentation
 - Chrome Free
 - Natural markings improved yield is the highest in the industry
 - Hides purchased exclusively from suppliers that adopt the Five Freedoms set of principles

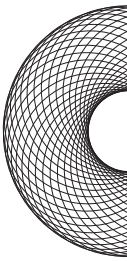



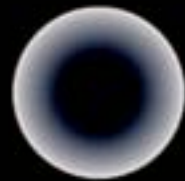
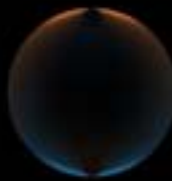
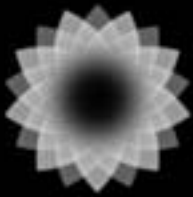

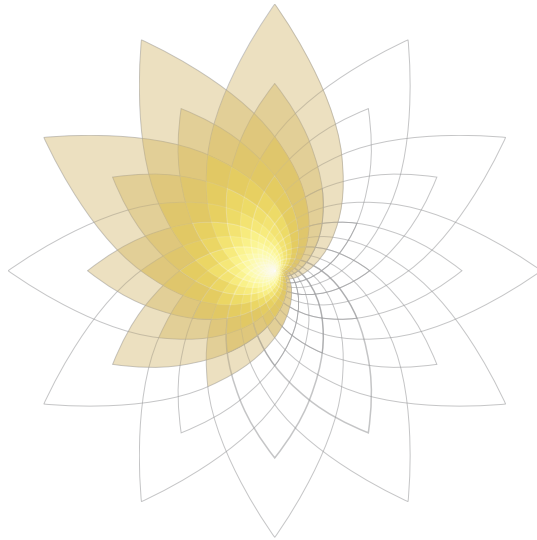

EXTERIOR

Solar Roof

The world's largest seamless solar glass roof for a production vehicle.

- Converts radiated power from the sun into stored electric energy effectively increasing vehicle range
- The solar roof charges the lithium-ion battery to regulate the interior climate control system
- Custom honeycomb design and color treatment complement every Karma paint option
- Can provide up to 200 miles (321km) of annual emission-free voltaic driving

Diamond Dust Paint

First manufacturer to offer recycled glass flake paint in a production vehicle.

- 35% to 55% recycled glass flake mixture
- 100% recyclable dry powder
- Water-based paint releases zero volatile organic compounds
- Leads the industry in reflectivity, shine and gloss



AUDIO

INTERIOR SOUND

Premium audio system including:

- AM/FM/MP3/USB/AUX Connectivity/Satellite
- Steering wheel audio and hands free controls
- Driver Infotainment system with 10.2" display

EXTERIOR SOUND

Fisker Hybrid HZ exterior speakers to warn nearby pedestrians/traffic.





SAFETY

Aluminum Frame

Lightweight extruded aluminum spaceframe developed by Norsk Hydro ASA.

- Uses 5000 and 6000 Series lightweight, high-strength aluminum alloys
- Central structural torque tube connects the front and rear frame sections
- Connected by 79 meters (259.2 feet) of precision welds and 1,058 self-piercing rivets

Brakes

- Antilock Brakes (ABS)
- Traction Control
- Electronic Stability Control (ESC)
- Brembo 6 piston monoblock (front)/ 4 piston (rear)/ 370 mm rotors front/356 mm rotors rear

Air Bags

Frontal dual-advanced restraint system with knee airbags, standard curtain and seat (pelvis/thorax) side airbags.

Safety Ratings

Designed to meet or exceed Global Crash Protection Standards (including rollover).



SPECIFICATIONS

Chassis

- Four-door, Four Passenger Sedan
- Lightweight Extruded Aluminum Spaceframe
- Lightweight Aluminum and Composite Body Panels
- Optimized, Lightweight Aluminum Design
- Energy Efficient, Modular Chassis Subassembly

Performance

- Stealth Mode:**
- Lithium-ion power only
 - 0-60mph = 7.9 sec
 - Top Speed = 95mph (153 km/h)
- Sport Mode**
- Lithium-ion power
 - Internal Combustion Engine (ICE)
 - 0-60mph = 5.9 sec
 - Top Speed = 125mph (200 km/h)

Range

- Stealth: 50 miles electric only (80km) - [100mpg (2.4L/100km) equivalent]
- Sport: 250 miles (402 km)
- Total Combined Range = 300 miles (483 km)

Powertrain

- Dual electric rear motors, rear wheel drive with mid-mounted battery pack and front/mid mounted Internal Combustion Engine (ICE)/Generator combination
- Electric Drive motors: 2x 150 kW (403 HP Total)
- Battery: 20 kW (Peak) Lithium-ion located longitudinally below floorpan along the centerline
- Gasoline Engine: 260 HP Turbocharged 2.0 liter Direct Injection
- Transmission: Single Speed Fixed Gear
- Linear opposed to exponential acceleration

Safety

- Front Dual Advanced Restraint System with Knee Airbags
- Standard Curtain and Seat (Pelvis/Thorax) Side Airbags
- ABS / Electro-Hydraulic Traction Control System / Electronic Stability Control (ESC)
- Lower Anchors & Tethers for Children (LATCH) system for three seating positions (front passenger & two in 2nd row)
- Design meets or exceeds Global Crash Protection Standards (including rollover)
- Lightweight aluminum frame

Wheels

- Custom Fisker designed 22 inch rims 255/35/R22 Goodyear 285/35/R22 Goodyear
- Tire Inflator Kit



Steering

- Hydraulically power-assisted and rack and pinion tuned for optimum control with programmable servo assist feature

Lighting

- Bi-Xenon headlamps
- Low-energy LED tail lamps and turn signals

Dimensions

- Overall Length: 196.7 in. (4996 mm)
- Overall Width: 78.1 in. (1984 mm)
- Overall Height: 52.4 in. (1330 mm)
- Front Overhang: 35.9 in. (913 mm)
- Rear Overhang: 36.3 in. (923 mm)
- Wheelbase: 124.4 in. (3160 mm)
- Front track: 66.6 in. (1692 mm)
- Rear track: 67.0 in. (1701 mm)

Suspension

- Load-leveling rear shock absorbers
- Mono-tube absorbers
- Tuned to control level of roll dampening
- Flat cornering with little body roll

Brakes

- Electro hydraulic brake boost unit with integrated chassis control function
- ABS, traction control, stability control
- Advanced regenerative blended brake system for maximum energy recapture and improved range
- Large (370mm) diameter vented rotors and 6-piston monoblock calipers
- Electrically actuated parking brake with capacitor back-up









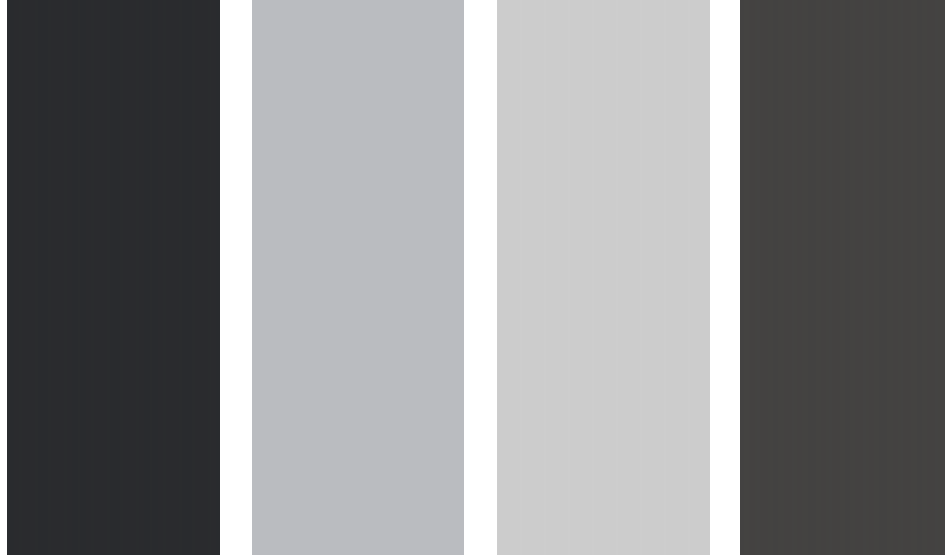

 Eclipse™

 Silver Wind™

 White Sand™

 Earth™

EXTERIOR COLORS

-  EcoChic
-  EcoSport
-  EcoStandard

 Inferno™



 Deep Ocean™

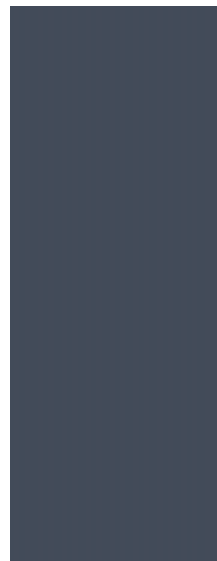

 Laguna™



 Shadow™



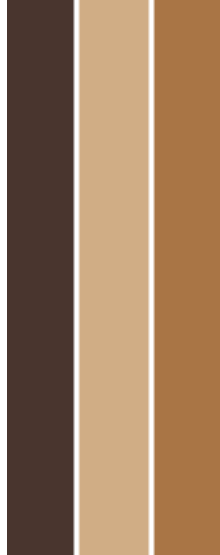

Canyon Tri-Tone™

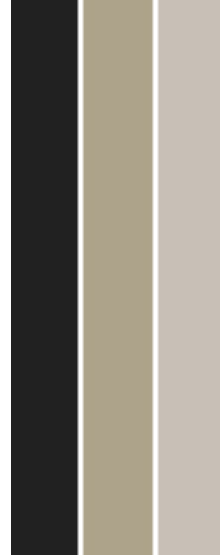

Monsoon Tri-Tone™

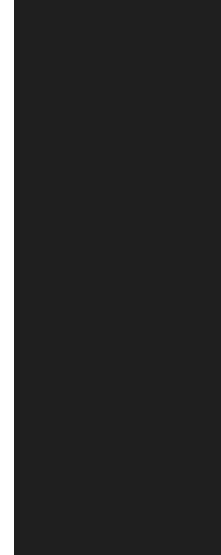

Black Sand Monotone™



Dune Monotone™

INTERIOR COLORS

- EcoChic
- EcoSport
- EcoStandard



Earth Tri-Tone™

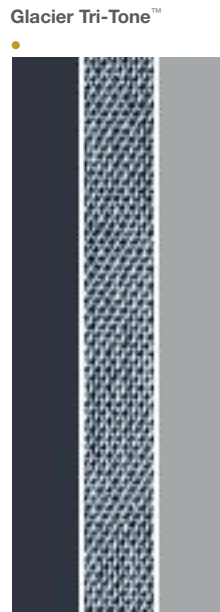

Glacier Tri-Tone™

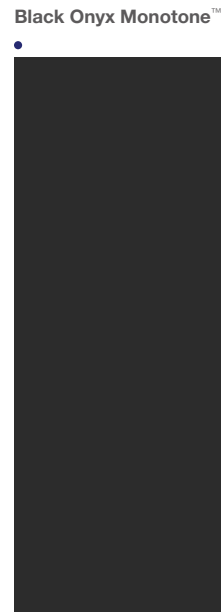

Black Onyx Monotone™

WOODS



Rescued Walnut Burl



Sunken White Oak



Fallen Mahogany



Deep Sunken White Oak



INTERIOR

EcoStandard

- Lightweight, animal-free interior environment designed to reflect pure leather grain
- Certified deep sunken wood from Lake Michigan
- Wing wood substrate made with recyclable post consumer pine fiber
- Contrasting surfaces and accent stitching
- Carpet backing made from recycled post consumer PET
- Seating foam made from soy-based bio fiber

Exterior Color Options:

- Eclipse™
- White Sand™

Interior Color Combinations

- Black Onyx Monotone™

EcoSport

- Hand-wrapped, premium leather from 100% sustainable processing plant
- Certified sunken wood from Lake Michigan or fallen wood from California storms
- Carpet backing from recycled post consumer materials
- Seating foam made from soy-based bio fiber

Exterior Color Options:

- Eclipse™
- White Sand™
- Silver Wind™
- Inferno™
- Deep Ocean™
- Shadow™
- Laguna™

Interior Color Combinations:

- Black Sand Monotone™
- Monsoon Tri-Tone™
- Canyon Tri-Tone™
- Dune Monotone™

EcoChic

The most advanced sustainable material trim package available.

- Animal-free execution which redefines and sets the benchmark for responsible luxury
- 100% Recycled post-industry virgin polyester Premium EcoSuede interior
- EcoSuede interior reduces energy consumption and CO2 emissions by 80% during the recycling process
- Certified rescued wood from California Wildfires
- EcoLucent™ Trim frames fossilized leaves in a unique, non-toxic, transparent material made from 40% post-industrial recycled content
- Carpet backing from recycled post consumer materials
- Seating foam from soy-based bio fiber content

Exterior Color Options:

- Eclipse™
- White Sand™
- Silver Wind™
- Inferno™
- Deep Ocean™
- Shadow™
- Laguna™
- Earth™ (Exclusive to EcoChic)

Interior Color Combinations:

- Earth Tri-Tone™
- Glacier Tri-Tone™

Standard Features

- Automatic Windows/Doors
- Keyless Ignition with Push Button Start
- Anti-lock, Regenerative Braking System
- Seat, Knee and Curtain Side Airbags
- Alarm System
- Standard 8 Speaker Audio Package

Comfort and Convenience Section

- Dual zone climate control
- Karma solar roof
- Tinted window glass with deep tint rear windows and backlite
- Auto dim rearview mirrors with heat and power fold
- Express up/down windows with pinch protection
- Body color exterior mirrors with heat and power fold
- 6 way heated power seat with power lumbar adjustment and three heat settings
- Heated rear seats
- Cruise control

- Interior lighting with parade mode and theatre dimming
- Illuminated entry and exit activated by key fob
- Turn signal tip blinking
- Electric passive entry door handles and keyless activation
- Remote start activates HVAC system in cabin and illuminates exterior parking lights to indicate remote preconditioning

Options

- Navigation
- Rear Camera
- Premium Audio Package



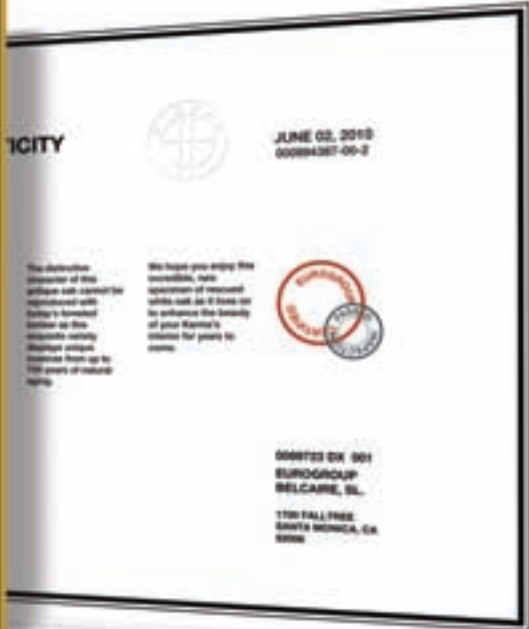

Letter of Authenticity

All Fisker Karma owners receive certificates documenting the authenticity of the wood featured throughout the interior.



WARRANTY

New Vehicle Limited Bumper to Bumper Warranty is 50 months or 50,000 miles for U.S. market.

*Warranty for EU will be market competitive and announced later this year.

SERVICE

Fisker Certified Service Centers and Technicians are available at Local Retailers.



CONTACT

Fisker Automotive, Inc.
 Corporate Park Irvine, CA
 92606 USA
 Main Line: 714.888.4255
 Fax Line : 949.757.4230

Retailer/Distributor Inquiries Contact

Fisker Automotive looks to partner with retailers that have a track record of high customer satisfaction, proven premium/luxury automotive experience and retail facilities that can accommodate a Fisker experience. If you meet these qualifications, please feel free to submit your information, including the location you are interested in representing to retailerinquiry@fiskerautomotive.com or:

Fisker Automotive
 Retailer/Distributor
 Inquiries
 19 Corporate Park
 Irvine, CA 92606

Supplier Inquiries Contact

Please submit your company background information, including DUNS Number, location, primary products and services, contact name, company website, company certification, labor and supplier status to suppliers@fiskerautomotive.com or:

Fisker Automotive
 Supplier Inquiry
 19 Corporate Park
 Irvine, CA 92606



LEGAL

©2010 Fisker Automotive, Inc. The Fisker name, model names, and logo are registered trademarks. All rights reserved.

Any visitor to these Web pages may download, copy or transmit any portion of the material in the Web pages of Fisker Automotive, Inc. for informational and noncommercial personal purposes only. Each copy of these materials must retain all copyright and other proprietary notices contained therein. The text, images, audio files, animation files, video files and any other content including customer input and their arrangement on this site are the property of Fisker Automotive, Inc. and subject to copyright and other intellectual property protection. Furthermore, The Fisker name, model names and logo are registered trademarks.

These trademarks and other Fisker banners, logos, service marks, design marks and any other intellectual property belonging to the company, may not be modified, and they may not be used, downloaded, copied or distributed in any way except as an integral part of an authorized download, copy or transmission of material in these Web pages. No license to any Fisker Automotive, Inc. intellectual property has been granted by this site. No other use, copying or transmission, in whole or in part, of any material may be made without the express prior written permission of Fisker Automotive, Inc.

The information in these Web pages is intended for customers only and is provided 'AS IS' WITHOUT WARRANTY OF ANY KIND, EITHER EXPRESSED OR

IMPLIED. INCLUDING, BUT NOT LIMITED TO, WARRANTIES OF MERCHANTABILITY, FITNESS FOR A PARTICULAR PURPOSE OR NON-INFRINGEMENT OF THIRD PARTY RIGHTS. In no event shall Fisker Automotive, Inc. be liable to any person for any special, indirect or consequential damages relating to this material.

Any issues involving this site shall be governed by the laws of the United States of America, the state of California as may be applicable, and anybody using this site agrees that any lawsuit shall be litigated in state or federal court in California.

Fisker Automotive, Inc. will, subject to legal requirements, determine the Model Year designation of its vehicles. The Model Year designation on any

particular model may be longer or shorter than twelve months. Some vehicles pictured may contain non-U.S. equipment. Some models may be shown with optional equipment.

All of the information contained in this site is for information purposes only and in no way constitutes an offer to buy or sell Fisker vehicles. The purchase of any Fisker vehicle shall be subject to the terms and conditions of the applicable sale, lease or financing contract.

Fisker Automotive, Inc. may at any time change this information by updating this posting. Visitors are bound by any such revisions and therefore should periodically visit this page to review the then-current website information.

While Fisker Automotive, Inc. makes all reasonable efforts to provide accurate information on this site, there is no guarantee or warranty of accuracy. Furthermore, we do not assume any liability for the accuracy or completeness of information presented on this site.

Any rights not expressly granted herein are reserved.