



Koenigsegg



In 1994, Christian von Koenigsegg captivated the automotive world when he penned the original Koenigsegg Competition Coupe (CC). Four car generations later, the Agera is born.

The name Agera means “to take action” in Swedish and is short for the ancient Greek word ageratos (ageless) – two meanings quite suitable for a vehicle that shatters industry benchmarks and lays the foundation for Koenigsegg’s future.

A bespoke, 1.140 hp Koenigsegg DOHC bi-turbo V8 propels the newest iteration of the iconic Koenigsegg design into action. Sixty miles per hour passes in a scant three seconds as the Agera races towards a 273 mph speed ceiling.

With a list of patents and industry firsts, the Agera as a whole is truly greater than the sum of its parts. It is designed and engineered for trendsetters yearning for perfection, exclusivity, and an uncompromised driving experience.

SPIRIT OF PERFORMANCE

When I started developing the first Koenigsegg cars in 1994, I knew we had to be different and excel in many areas, in order to become what we are today.

At Koenigsegg, good is never enough. We strive for perfection and the moving target of ultimate performance, in every aspect. Whether it is emotion, speed, elegance, comfort or drivability – we make sure to raise the bar.

Each detail is lovingly honed to perfection. We combine extreme attention to detail with focus and passion.

All available time, emotion, and resources have been spent. Nothing has been spared – everything has been ventured and sacrificed – in order to create a car beyond imagination.

I truly feel that our cars have souls. We have poured our hearts into them.

You will feel it when driving one.



Christian v. Koenigsegg

AERODYNAMICS

Over 17 years of computational fluid dynamics and real wind tunnel testing evolved the original Koenigsegg CC into the Agera. It features a refined profile and several new features to improve the aerodynamic capability at all speeds.

"The Agera R gets 5 out of 5 stars" EVO

Vents over wheel arches to reduce drag and increase downforce.

Panoramic windshield.

Dynamically movable wing.



Super efficient water cooling system with minimal drag.

Cut out in splitter to ensure the airflow reaches the rear diffuser during braking.

Hydraulic ride height control with different performance settings.

Large side intakes ensure that the pressure point of the car is behind the mass center. This adds directional stability with increasing speed and massive airflow to the inter coolers and oil coolers.

Front splitter promoting constant down force.

Aircore™ carbon fiber wheel. An industry first. Reduces unsprung mass and increase performance. The worlds lightest and strongest road car wheels.

Large air intakes for brake cooling.

A HIGHLY SOPHISTICATED MACHINE

Genetically dissimilar from the rest of the automotive world, the Agera truly stands out. Patents and countless bespoke programs, methods, and technologies protect it as a unique masterpiece.

In a world of cross pollination between vehicle manufacturers, Koenigsegg's engineers rebel by developing the Agera's systems internally to preserve technological integrity and superiority.

From the bespoke 1,140 hp powerplant to the world's quickest traction control system, each component is designed and qualified in Ångelholm, Sweden.

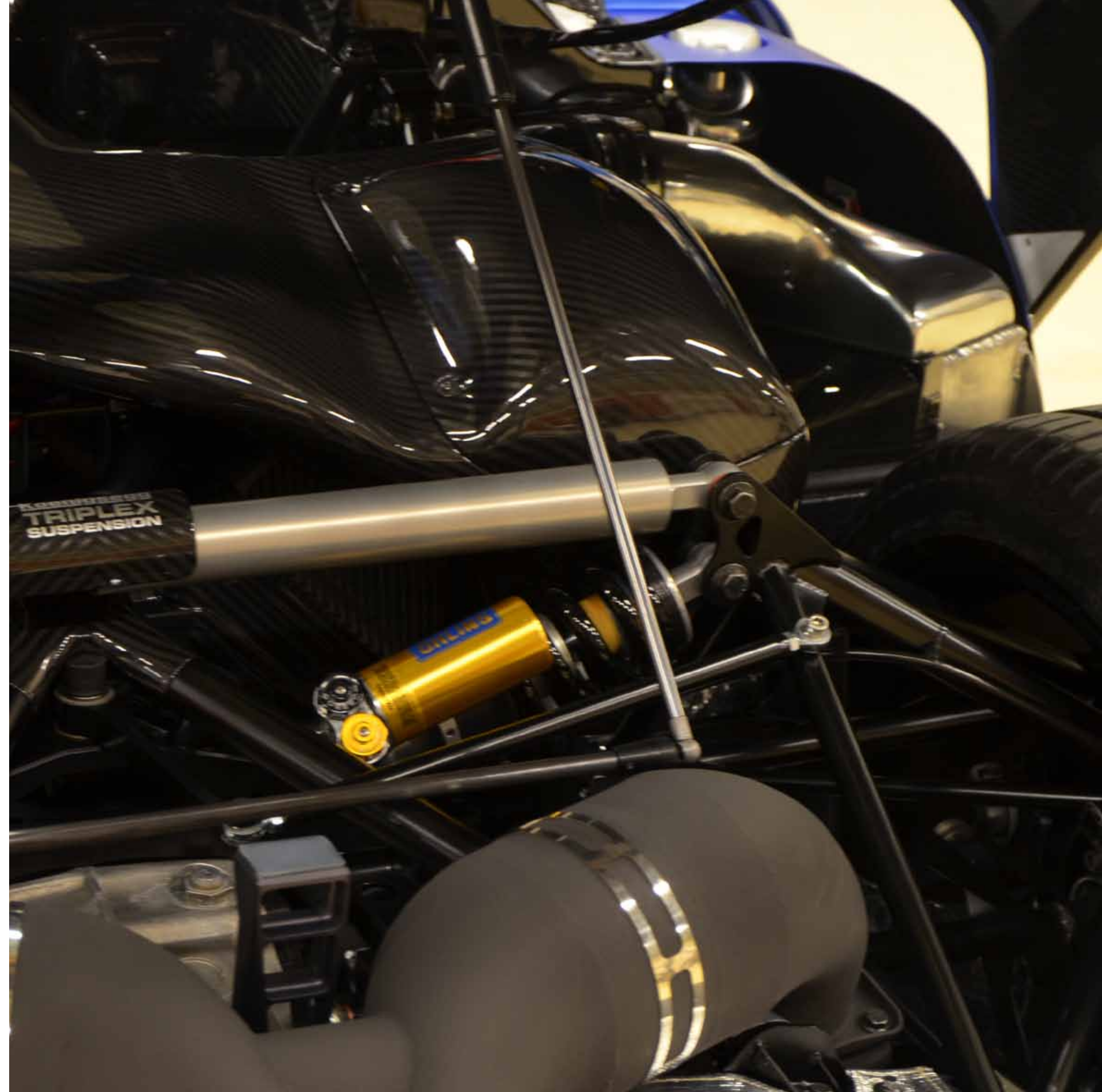



A HANDCRAFTED HYPERCAR

For those who truly appreciate the dedication of an automotive masterpiece that perfectly combines technology & design into the most exhilarating driving experience available today, the Koenigsegg Agera is their choice.

Seven stages of production occur over three months at the production facility in Ångelholm. Just a few pair of hands - belonging to specialized automotive artisans - spend 3000 hours to bring each Agera to life.

Meticulous attention to detail ensures that over 4000 custom parts come together in a perfect harmony of high tech and classical craftsmanship.



THE DESIGN

Over the past 17 years Koenigsegg has become an instantly identifiable icon synonymous with style, performance, and exclusivity. The Agera honors its predecessors and stays true to Swedish functionalist design. By strictly adhering to the minimalist "less is more" philosophy Christian von Koenigsegg ensured the Agera to be purposefully beautiful.

The Agera is the perfect representation of modern advances in aerodynamics merged seamlessly with contemporary aesthetics.



* Shown with optional custom ski box.



"The Agera will destroy almost anything on track if the driver is good enough" Motortrend

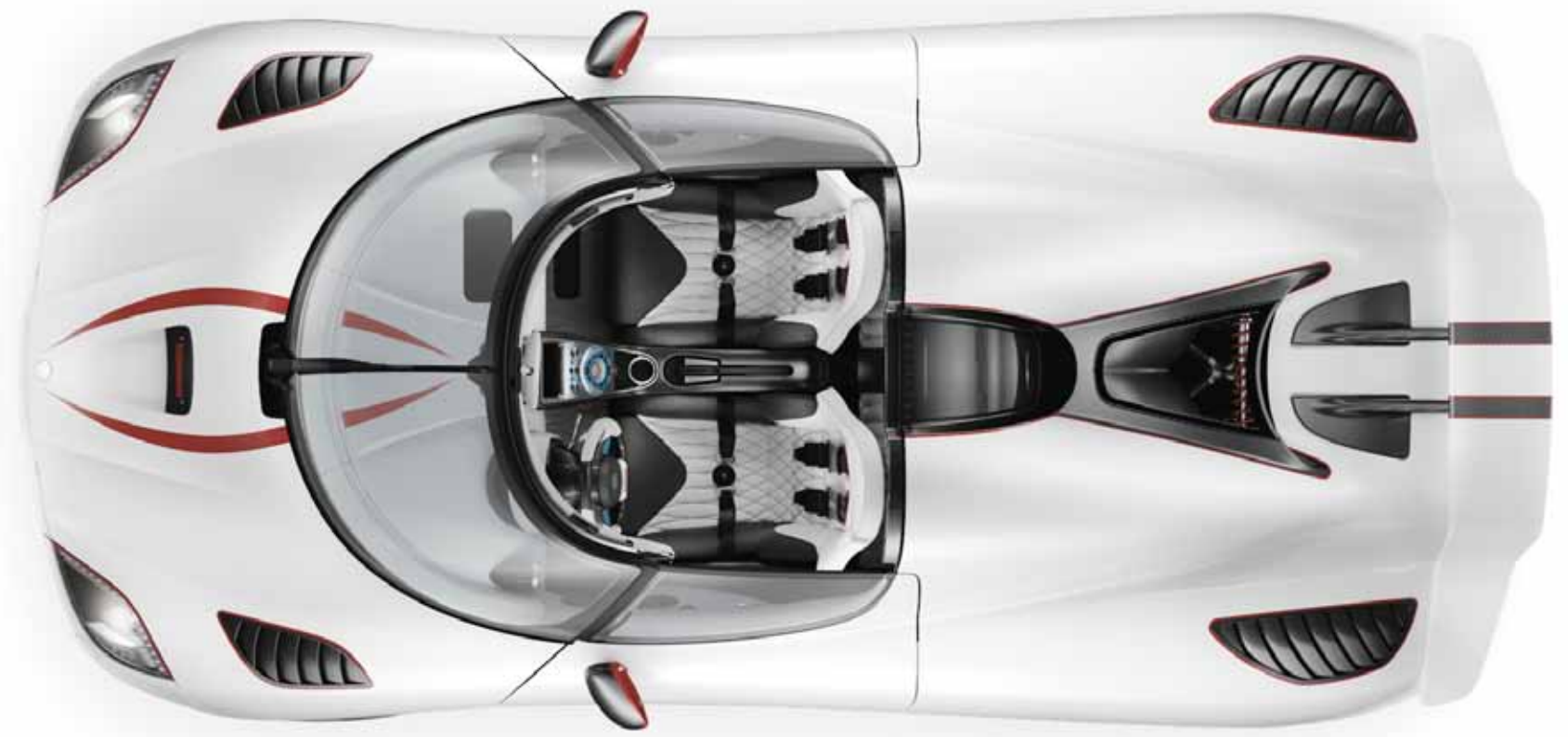
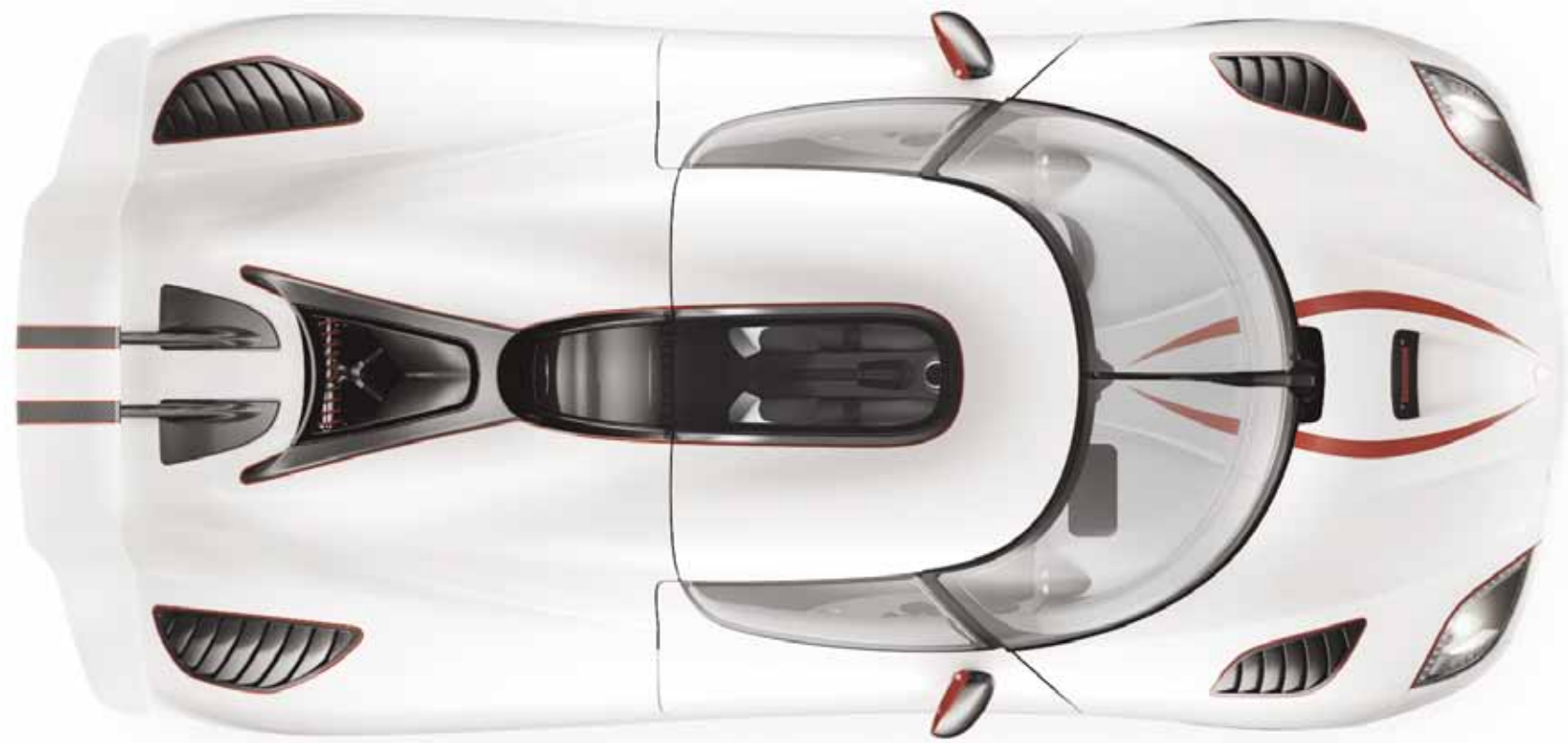

TWO CARS IN ONE

The stiffest production car chassis on the planet allows the Agera to be versatile without compromise. Its one-piece carbon fiber roof quickly stows under the bonnet to reveal a roadster. No other Hypercar carries its hardtop while in roadster form.

DIHEDRAL SYNCHROHELIX DOORS

The awe-inspiring, elegantly smooth movement of the Dihedral Synchrohelix doors defies convention.

Following Koenigsegg's functional design mantra, this trademark feature has minimal door swing with a more spacious opening.

"The Agera R is likely as fast and exiting as your body can handle. It is also a surprisingly polished product" EVO





"The acceleration of the Koenigsegg is unreal" Sportauto

SPIRIT OF THE GHOST

In the 1940's – the Swedish Air Force pilots, belonging to Ängelholm's first squadron – took off just before dawn, climbing through the dark, searching for the first sunlight at the horizon. People on the ground called them the ghost-fighters. Just a shadow passing by, they left nothing but a distant roar. Their symbol became the Ghost, and they wore it with pride on their jets.

When Koenigsegg took over the former home base of the retired Ghost Squadron, Koenigsegg was asked to keep the spirit of the Ghost alive. Each Agera pays homage to the Ghost Squadron by wearing its insignia on the glass above the engine bay.



POWERTRAIN

Koenigsegg is the only limited volume manufacturer to develop its powertrain in-house.

The Agera's heart is a bi-turbo DOHC 8 cylinder engine producing over one thousand one hundred horsepower. A symphony of innovative technology transfers the tremendous power to the road, yielding the world's fastest accelerating production car.

The Agera R's colossal 1,140 horsepower and earth moving 1200 Nm (855 lb-ft) of torque launch it to 60 mph in a mere 2.8 seconds. 0 - 200 mph takes 17.68 seconds and 0 - 300 km/h a mere 14.53 seconds, both are world records.

Contrary to common sense, no other production engine in the world offers the same power compared to emissions or fuel consumption.

Koenigsegg's highly qualified engineering team relentlessly developed the Agera's engine for power, drivability, and longevity. Each engine is hand assembled in Ångelholm by a master engine builder to ensure exact tolerances and unprecedented quality.

The Agera engine package is the lightest, most compact Hyper-car engine in the world. Complete with clutch, flywheel, dry sump system, and Inconel manifold system (with turbos) it weighs less than 200 kg (440 lbs).

The Agera's class leading fuel consumption of around 20 mpg and 80 litres (21 gallons) fuel tank provide excellent range.

Large air-to-air intercoolers keep the Agera cool even during extended performance driving, and by eliminating the need for water in the intercooling system, saving a significant amount of weight.

Koenigsegg's patent pending response/backpressure reduction system and the latest generation turbocharging technology provide instantaneous turbo response for seamless power delivery.

Koenigsegg's dry sump lubrication system provides a constant supply of oil during high lateral g-force cornering.

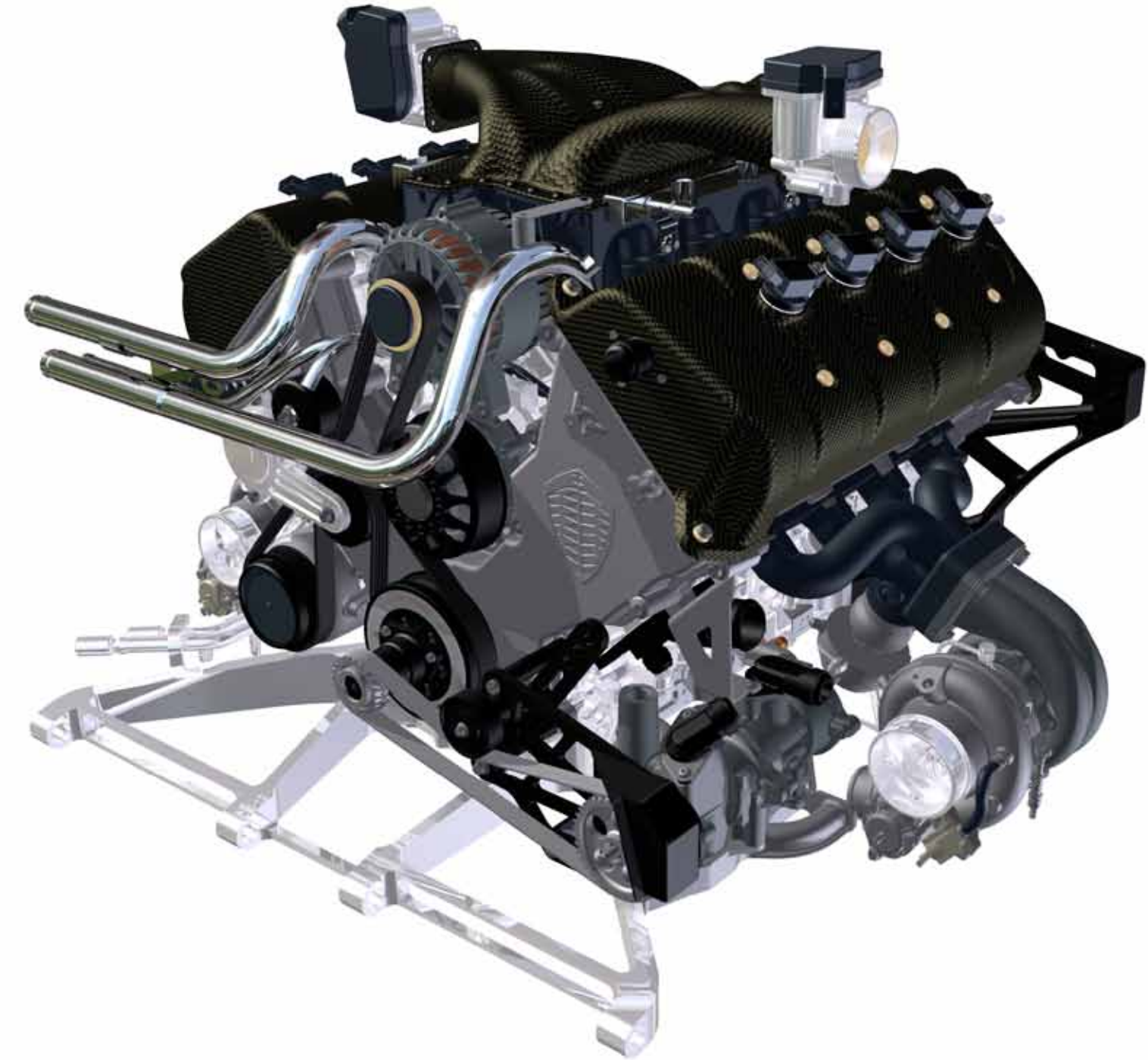

GEARBOX

While providing extremely fast and smooth shifts, the new 7-speed paddleshift gearbox is lighter and more compact than any other Hypercar transmission – weighing a mere 81 kg. It uses Formula 1 spec materials for both gears and shafts in order to cope with over 1200 Nm of torque.

WET CLUTCH SYSTEM

The Agera gearbox features the world's first dual clutch system designed for a single input shaft gearbox.

During each upshift a hydraulic wet clutch inside the gearbox is engaged to slow down the input shaft. This pre-synchronization cuts the shift time by two thirds. Despite its immense capabilities, this sophisticated system can operate as a fully automatic gearbox with the mere push of a button.

ELECTRONIC DIFFERENTIAL

The Agera's E-Differential is an industry first. It combines a traditional limited slip differential with a revolutionary, active digital system to minimize both weight and reaction time.

The digital system is programmed with algorithms, designed by Koenigsegg, to analyze multiple inputs including throttle angle, g-force, steering wheel angle, car speed, yaw angle, engine rpm, selected gear, and weather conditions to command the E-Diff.

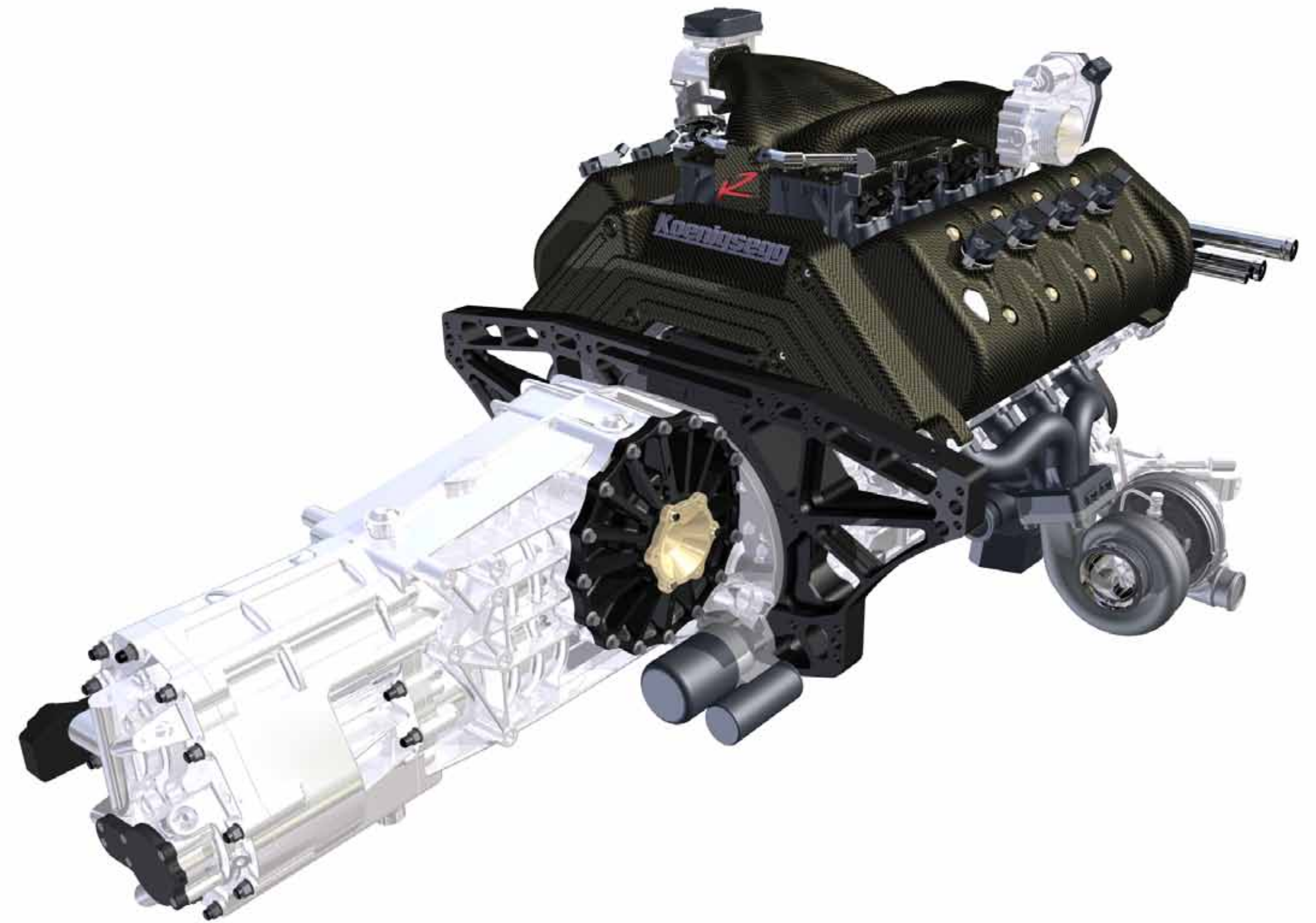

6 NEW WORLD RECORDS FOR KOENIGSEGG

On the 2nd of September 2011 at 12.08 pm, the Koenigsegg Agera R took several new production car world records at the Koenigsegg proving ground in Ångelholm, Sweden. All data was measured and collected by a third party. The records truly show the Agera R's phenomenal stability, acceleration and braking performance - and that its performance is in a league of its own.



The numbers are as follows:

0-300 km/h = 14.53 sec
0-200 mph = 17.68 sec
300-0 km/h = 6.66 sec
200-0 mph = 7.28 sec
0-300-0 km/h = 21.19 sec
0-200-0 mph = 24.96 sec



"In a span of just 24.96 seconds, you can hit 200-mph and comeback down to zero. Astonishing!" Autoguide.com



"Even an acceleration from 250 km/h feels like you are being catapulted off the deck of an aircraft carrier" Prestige Cars

HIGH-TECH THUNDER

The Agera's patent-pending Inconel/titanium exhaust system is engineered and fine-tuned to unleash Koenigsegg's signature thunderous growl.

It achieves remarkably low emissions and yet maintains high power levels due to its earlier catalytic light-off and drastically reduced back pressure, more than any other turbo exhaust system in the world.



"It becomes addictive and the car will cover ground at a rate the authorities will find unacceptable" EVO



"The Agera is the most exciting supercar on earth, bar none" Top Gear



The Koenigsegg crest design is based on the Koenigsegg family coat of arms from the 12th century.



"The acceleration of the Koenigsegg is unreal" Sportauto

CI-CONFIGURABLE INSTRUMENTS

The Agera's configurable instruments, CI, feature various display layouts designed to meet the driver's specific demands.

Pressing the left stalk button changes the dash layout. Track driving mode prioritizes RPM, pressures, temperatures, lap times, and g-forces. GT driving mode focuses on speed, satellite navigation, and music.



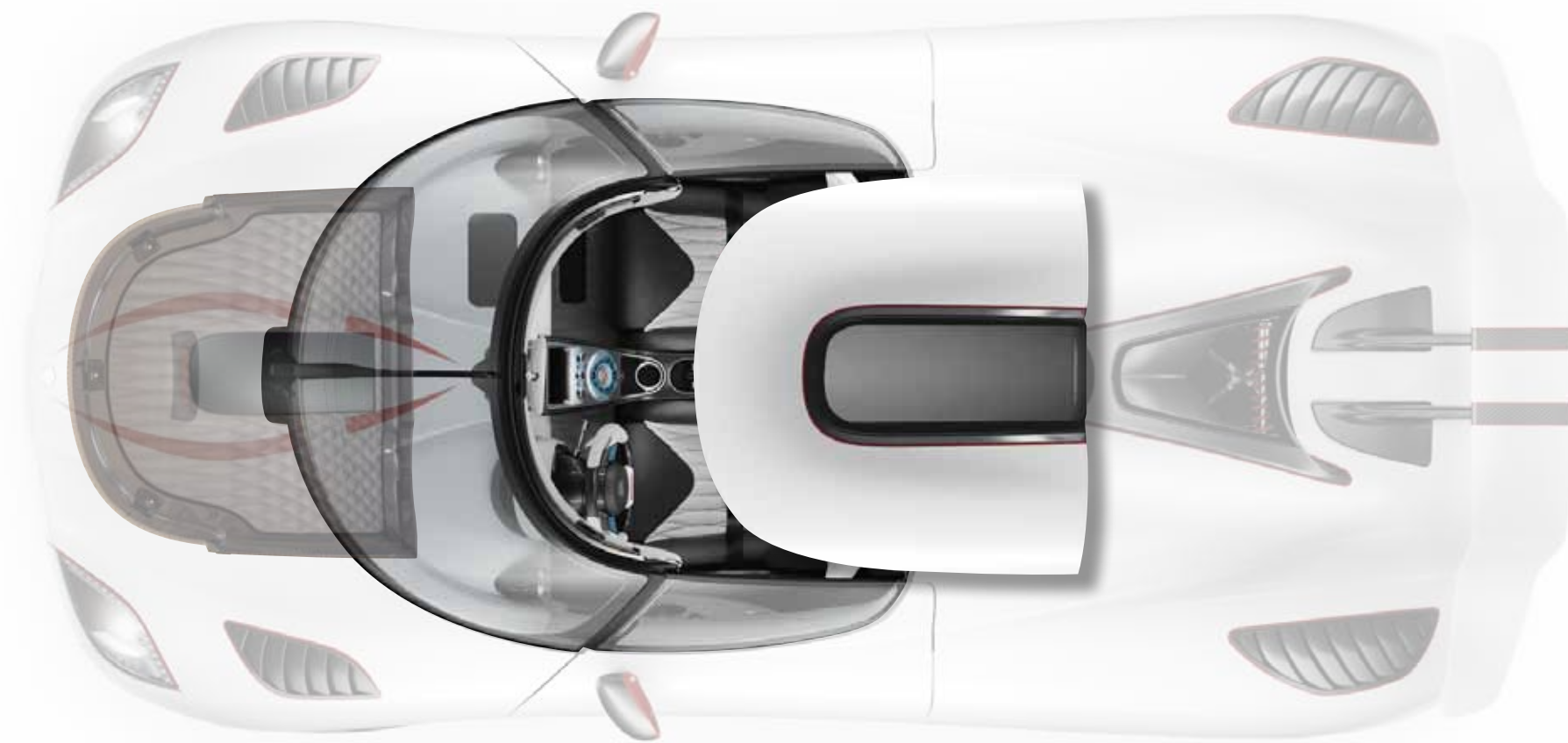

The roof is easily removed and it is designed to stow away perfectly in the front luggage compartment. This unique and practical feature sets the Koenigsegg Agera R apart from all other hypercars.

The roof is also equipped with a roof lock warning system to alert the driver if the roof is not securely fastened when the car is in motion.

THE COCKPIT

The Agera's interior design follows Koenigsegg's less-is-more philosophy. Everything serves a functional purpose; there is no distracting visual drama. At Koenigsegg, this is the essence of beauty.

The Agera's interior is like no other.

Innovative technology such as the multifunctional infotainment system and configurable instruments provide unsurpassed functionality. The newly designed steering wheel and seats are prime examples of Swedish ergonomics; they are the perfect combination of comfort and support. Only the finest materials are deemed worthy for use in the Agera's interior. Everything between the headliner and carpet is adorned in either carbon fiber, precious metals, alcantara, billet aluminum, or aniline leather.

At Koenigsegg, we relentlessly pursue the ultimate in performance. The applies to our interiors as much as it does to our engines, aerodynamics or suspension systems. We dare you to find an interior better suited to the world's premier driving experience.

PACK YOUR BAGS

A 120 liter (> 4 cubic feet) luggage capacity eclipses every other car in the class. Pack your bags for a week.



"The Agera R's interior is spacious and the quality feel is tremendous" Teknikens Värld



SEATS

The Agera's stylish, carbon adjustable seats strike the perfect balance between comfort and support.

The aniline leather and sporty alcantara inserts feature elongated diamond stitching with the Koenigsegg crest adorning the head rest.

A lightweight, rigid, carbon fiber shell supports our specifically engineered ergonomic foam. This provides plush comfort for long trips as well as exceptional lateral support against the 1.6g's that the Agera is capable of generating.

The Agera R comes with standard seat belts and removable, 4-point racing harnesses.

COMMAND CENTER

The 7 inch high-definition touch screen is a hub for all vehicle information and the command center for controlling all elements of the Agera. From accessing your phonebook via Bluetooth and playing your favorite song to changing drive mode and tracking your performance – it's all there.

While featuring auto-adapt functionality, the Agera's traction control system also allows manual settings for racetrack performance.





"The helmet visor-like windscreen gives an undisturbed panoramic view ahead" CAR

STEERING WHEEL

The new super light full carbon airbag steering wheel provides the driver direct access to primary functions and is illuminated by way of Ghost Light.

The entire steering wheel and dash telescopes in unison, never obstructing the dash with the steering wheel.

HANDS ON CONTROL

Gripping the new all carbon steering wheel puts the world record performance of the Agera in your hands. The flat-bottom design incorporates vital functions and raised thumb rests.

Paddle shifters are mounted directly on the back of the steering wheel enabling shifting without taking your hands off the steering wheel while cornering.

"An holistic approach has helped Koenigsegg to create one of the finest cars in the world" Motortrend

GHOST LIGHT

Another unique feature of the Agera is the Koenigsegg Ghost Light. The Ghost Light is a world's first in the car industry. The LED illumination shines through the billet aluminum buttons and surfaces out of nowhere by way of almost invisible micro holes. It creates excellent visibility of the symbols as well as being very clean and stylish. It's all framed by an all new carbon fibre centre console and tunnel assembly.

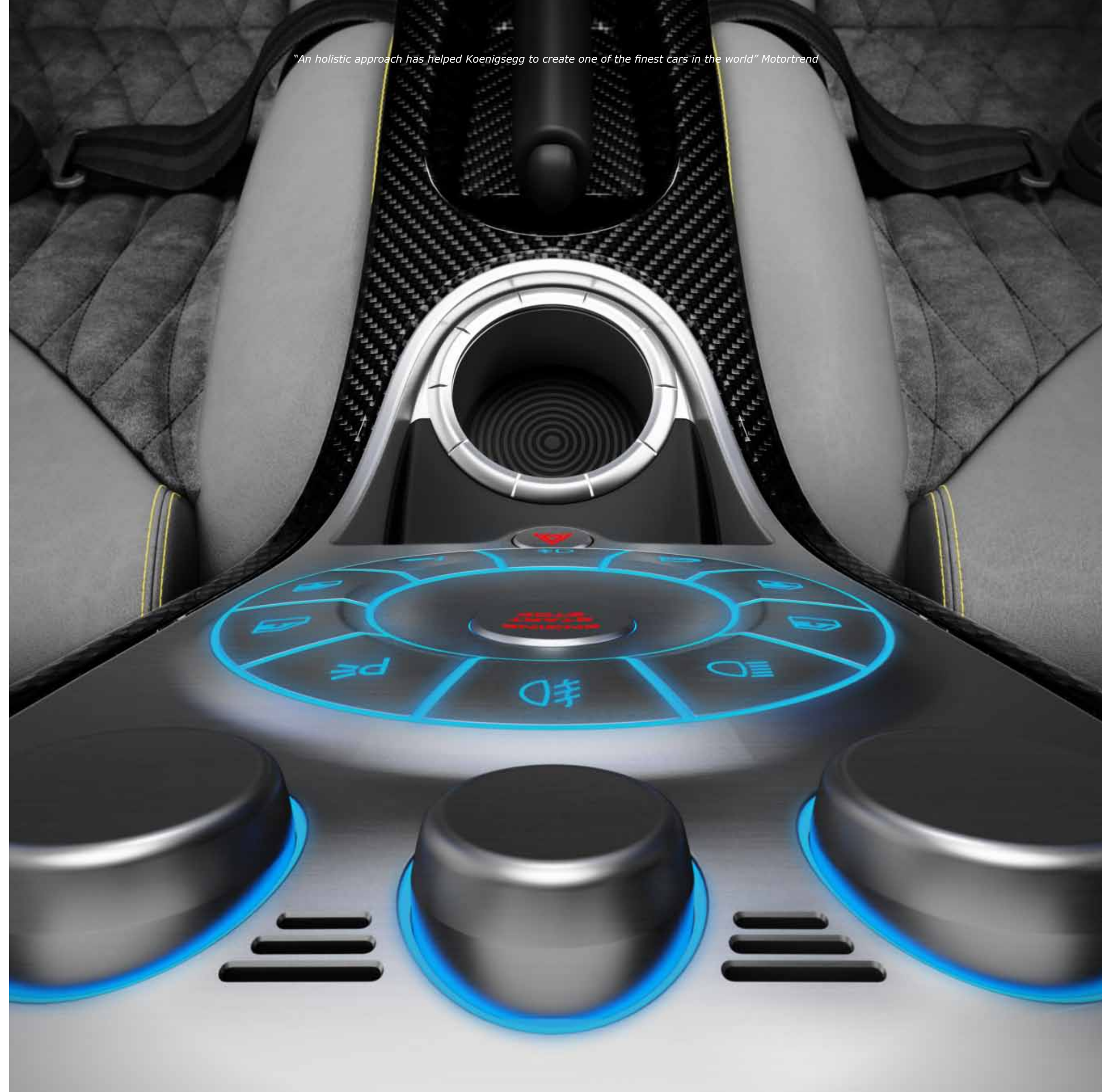



DYNAMIC REAR WING SYSTEM

Unlike heavy pre-programmed hydraulic systems, the lightweight Dynamic Rear Wing adjusts its angle of attack with actual wind pressure. It compensates for headwind or tailwind making it more reactive than pre-programmed systems.

The dual carbon fiber pylons act as engine heat channels. Hot engine bay air rushes past the pylons causing a Venturi effect which increases the flow of cool air through the side radiators. This reduces the pressure under the Agera and adds low-drag down-force.

REAR DIFFUSER

The rear diffuser was specifically developed and evaluated to provide substantial all around down force even at wide yaw angles.

SUSPENSION

The Agera's suspension combines proven Koenigsegg suspension geometry and innovative advances in suspension technology. It features F1 style wishbones, uprights, record setting brakes, and industry leading active control systems.

The Agera R features the Koenigsegg exclusive triplex rear suspension, further enhancing body control and agility.

WISHBONES

The Agera's wishbones are inspired by F1 design and are the longest of all supercars in production. While allowing for less track width deviation during wheel movement and cornering, they improve geometry over a longer wheel stroke. Minimizing weight and maximizing stiffness and strength by utilizing aeronautical chrome-molybdenum tubing.



"The massive grip generated by the chassis, instills instant confidence" Autocar

UPRIGHTS

The extremely strong and light uprights are machined from 7075-T6 aeronautical grade aluminum. Normally only found on Le Mans prototype cars, the 240 mm SKF dual angle contact bearings add to the wheel assembly's stiffness, providing better control, handling, and comfort. The uprights also incorporate large 4.5" diameter carbon fibre brake cooling ducts to maximize brake cooling.

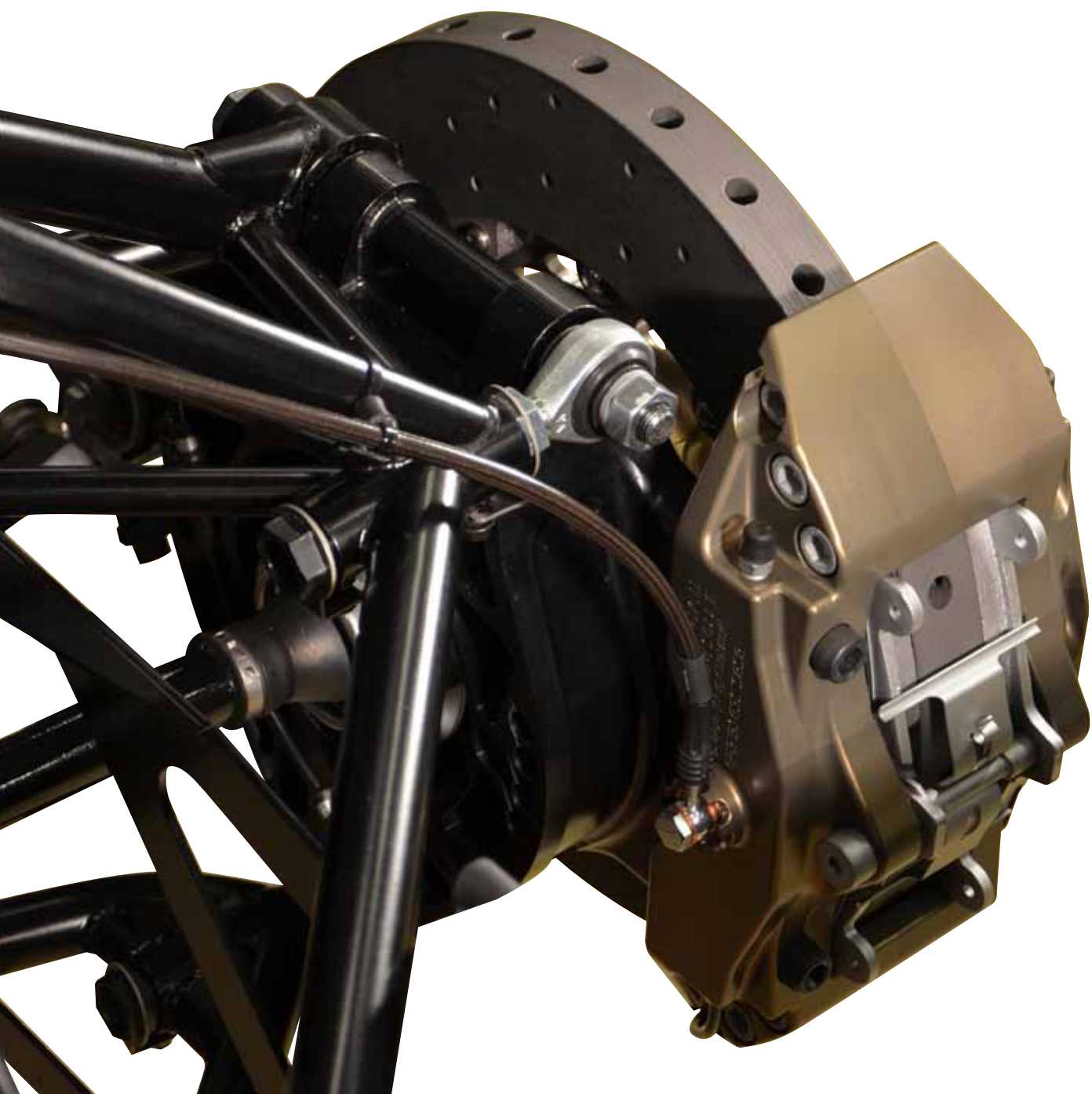

BRAKES

The Agera is the fastest stopping supercar in existence. It is equipped with the absolute latest ABS technology that reacts differently depending on performance mode. The massive 392×38 mm and 380×34 mm ventilated and drilled ceramic discs and billet aluminum 6 piston front/4 piston rear calipers provide world record braking performance and zero fade regardless of track or road condition.

The Agera stops from 200 mph in a world record time of only 7.28 seconds.



THE STIFFEST AND LIGHTEST HYPERCAR CHASSIS, EVER

The Agera's unique carbon fiber monocoque chassis is designed to achieve maximum stiffness of 65,000 newton meters per degree with or without its roof. It weighs only 70 kg with its integrated fuel tanks.

Formula 1 carbon fiber monocoques are constructed with aluminum honeycomb to achieve high stiffness and safety levels. The Agera is the only Hypercar in the world to utilize aluminum honeycomb in its monocoque.

The process is extremely difficult and tedious, but being the best is never easy.



"For such a light car the Koenigsegg has a satisfyingly weighty feel, through the steering but also in the way its planted on the road" EVO

Performance

Power output: 960 hp at 7100 rpm - redline @ 7500 rpm
 Torque: over 1000 Nm from 2700 to 6170 rpm
 Max torque: 1100 Nm at 4000 rpm
 Acceleration: 0-100 km/h (0-62 mph) 3 sec
 0-200 km/h 8.0 sec, 0-200-0 km/h 13.5 sec
 Braking distance: 30.5m (100-0 km/h)
 Lateral g-force: 1.5 g
 Fuel consumption: Highway travel: 12,5 l/100km,
 Combined: 14,7/100km
 Weight-to-power ratio: 1.49 kg/hp (dry weight)
 Weight distribution: 46% front, 56% rear
 Emission levels: Euro V and lev 2

Aerodynamics

Cd. 0,33
 Frontal Area: 1.873 m2
 Total Downforce at 250 km/h: 300 kg
 Flat underside of chassis. Venturi tunnels at rear of chassis/body.

Dimensions

Total length: 4293 mm (169")
 Total width: 1996 mm (78.6")
 Total height: 1120 mm (44.1")
 Ground clearance: Rear: 100 mm (3.94") Front: 100 mm (3.94")
 Wheelbase: 2662 mm.
 Front track: 1700 mm. Rear track: 1650 mm.
 Front overhang: 885mm Rear overhang: 752mm
 Fuel capacity: 80 litres
 Luggage compartment: 120 litres (31.7 US gallons)
 Dry weight: 1330 kg
 Curb weight 1435 kg (all fluids plus 50% fuel)
 Maximum laden weight: 1650 kg (full tank, two passengers, full luggage)

Chassis

Carbon fibre with aluminium honeycomb and integrated fuel tanks for optimal weight distribution and safety.
 Monocoque torsional rigidity: 65,000 Nm/degree.
 Weight including tanks: 70 kg.
 Front and rear suspension: Double wishbones, two-way adjustable gas-hydraulic shock absorbers, pushrod operated.
 Electronically adjustable ride height.
 Front: Cro-Mo subframe, with integrated crash members.
 Rear: Semi-stressed engine and gearbox with support struts, for needle bearings and o-ringed wishbone bushings optimal rigidity and no engine inertia movements.
 Fully machined aircraft aluminium uprights, with SKF LeMans specification 150mm angle contact ball bearings.
 GKN hollow/gun-drilled driveshafts.
 Koenigsegg Z-style progressive and lightweight anti-roll bars front and rear.

Engine

Koenigsegg aluminum 5,0L V8, 4 valves per cylinder, double overheadcamshafts
 Compression: 9.0:1
 Bore: 91.7 mm Stroke: 95.25 mm
 Sequential, multipoint fuel injection.
 Twin turbo superchargers
 1.3 bar boost pressure.
 Dry sump lubrication.
 Carbon fibre intake manifold with optimised intake tracts.

Tig-welded ceramic coated inconel exhaust system manifold with merge collector.
 Weight: 197 kg

Transmission

Specially developed 7-speed dual clutch, 1 input shaft transmission with paddle-shift.
 Electronic differential.

Steering

Rack and pinion power assisted steering. 2.7 turns lock-to-lock.
 Turning circle: 11 metres. TRW electro-hydraulic power-assisted.

Brakes

Front brakes: Ventilated ceramic discs Ø 392 mm, 38 mm wide. 6-piston calipers. Power-assisted.
 Rear brakes: Ventilated ceramic discs Ø 380 mm, 34 mm wide. 4-piston callipers. Power-assisted.

Traction Control

F1-style for optimal performance with 5 different handling modes.

Wheels

Koenigsegg forged Vortex generating aluminium wheels with centre locking
 Front: 19" x 9.5"
 Rear: 20" x 12.5"

Tyres

Dedicated Michelin Supersport
 Unidirectional with asymmetric thread pattern
 Front: 265/35 – 19" (Y)
 Rear: 345/30 – 20" (Y)
 Speed rating: 420+ km/h

Body

Two-door, two seater with removable hardtop stowable under the front hood lid. Body made from pre-impregnated carbon fibre/kevlar and lightweight sandwich reinforcements. Carbon vents over wheels.

Electrical System

Solid state digital semiconductors - no fuses or relays.
 Can bus operated and fully programmable functionality.

Equipment

Dual airbags, detachable storable hardtop with glass roof, power windows, rear wing, adjustable pedals and steering column, Agera stitching, adjustable seats in rake and length, carbon ceramic brakes with Sport ABS, EPS, Intelligent LifePo4 battery, hydraulic lifting system, power steering, power brakes, Satnav, MP3 player, USB connection, climate control, digital warning and info system, G sensor, alarm, tyre monitoring system, silver key, leather carpets, roof storage bag, car cover, Inconel exhaust system, rear view camera.

Extra Equipment

Fitted luggage, special leather and colour requests, Triplex rear suspension, heated seats, ski box roof, skis, winter wheel package, 4 point racing harnesses.

3 Year Warranty.

All information correct at time of printing, and subject to change.

Agera



"Absolute magic - devastatingly fast" Automobil



THE R PACKAGE

All the features and functionality of the Agera with a few more unique solutions to push the performance even further.

Engine Upgrade

In 2007 Koenigsegg introduced the bio fuel CCXR and became the first sports car manufacturer to move towards green technology. The Agera R engine utilizes Koenigsegg's latest generation of bio fuel engine management system. While generating 1140 hp and 1200 Nm of torque on E85 and E100 bio fuel it also runs on 95 octane pump gas to produce 960 hp and 1100 Nm of torque. The Agera R is truly flex fuel.

Triplex rear suspension

Koenigsegg has invented a new type of rear suspension system for a road car called the Triplex rear suspension. It utilizes a shock absorber and spring to link the rear wheels allowing the rear wheels to influence one another.

This results in increased comfort and better handling on rough and wet surfaces without compromising dry track handling. Furthermore the Triplex system has an anti-squat effect. Traditional anti-squat systems are designed into the geometry of the suspension. By adding the Triplex system, Koenigsegg maintains true suspension geometries. The Triplex system complements the normal dampers and springs, allowing them to be made lighter.

Dynamic rear wing

Unlike heavy pre-programmed hydraulic systems, the lightweight Dynamic Rear Wing adjusts its angle of attack with actual wind pressure. It compensates for headwind or tailwind making it more accurate than pre-programmed systems.

Aircore carbon wheels

The Koenigsegg Aircore™ wheels are the world's lightest and strongest production car wheels ever made. The spokes and hubs are hollow, hence the name Aircore™. The Aircore™ carbon wheels save just over 20 kg compared to the already very lightweight and forged Koenigsegg wheels, making the whole car lighter, in the most important positions.

Agera R side winglets

The Agera R comes standard with Koenigsegg's latest carbon front winglets mounted on the radiator outlets. These winglets not only give 20 kg more down force at 250km/h, but also reduce drag, making them a true win-win installation.

Partial visible carbon body work

The Agera R has a unique clearcarbon side treatment that differentiate it from all other Koenigsegg cars. The large side airintake is fully visible carbon and this blends nicely in with the visible carbon rear end of the car.

Agera R Aero Exhaust

The 2013 Agera R comes equipped with a new one piece exhaust outlet. Not only is this outlet lighter, it is also shaped to improve underbody air release and work in conjunction with the Carbon air diffusers which flank the exhaust outlet.

R Badges and Paint Scheme

Apart from the technical differences, the Agera R is also adorned in R badges and features a custom partially visible carbon paint scheme.

Performance

Power output: 1140 hp at 7100 rpm - redline @ 7500 rpm
 Torque: over 1000 Nm from 2700 to 6170 rpm
 Max torque: 1200 Nm at 4100 rpm
 Acceleration: 0-100 km/h (0-62 mph) 2.9 sec
 0-200 km/h 7,5 sec, 0-200-0 km/h 12.3 sec
 0-300-0 km/h 21,19 sec
 Braking distance: 30.5m (100-0 km/h)
 Lateral g-force: 1.6 g
 Fuel consumption: Highway travel: 12,5 l/100km,
 Combined: 14,7/100km
 Weight-to-power ratio: 1.24 kg/hp (dry weight)
 Weight distribution: 44% front, 56% rear
 Emission levels: Euro V and lev 2

Aerodynamics

Cd. 0,33 to 0,37 with adaptable rear wings.
 Frontal Area: 1.873 m2
 Total Downforce at 250 km/h: 300 kg
 Flat underside of chassis. Venturi tunnels at rear of chassis/body.

Dimensions

Total length: 4293 mm (169")
 Total width: 1996 mm (78.6")
 Total height: 1120 mm (44.1")
 Ground clearance: Rear: 100 mm (3.94") Front: 100 mm (3.94")
 Wheelbase: 2662 mm.
 Front track: 1700 mm. Rear track: 1650 mm.
 Front overhang: 885mm Rear overhang: 752mm
 Fuel capacity: 80 litres
 Luggage compartment: 120 litres (31.7 US gallons)
 Dry weight: 1330 kg
 Curb weight 1415 kg (all fluids plus 50% fuel)
 Maximum laden weight: 1650 kg (full tank, two passengers,
 full luggage)

Chassis

Carbon fibre with aluminium honeycomb and integrated fuel tanks for optimal weight distribution and safety.
 Monocoque torsional rigidity: 65,000 Nm/degree.
 Weight including tanks: 70 kg.
 Front and rear suspension: Double wishbones, two-way adjustable gas-hydraulic shock absorbers, pushrod operated.
 Triplex damper in the rear.
 Electronically adjustable ride height. Front: Cro-Mo subframe, with integrated crash members.
 Rear: Semi-stressed engine and gearbox with support struts, for needle bearings and o-ringed wishbone bushings optimal rigidity and no engine inertia movements.
 Fully machined aircraft aluminium uprights, with SKF LeMans specification 150mm angle contact ball bearings.
 GKN hollow/gun-drilled driveshafts.
 Koenigsegg Z-style progressive and lightweight anti-roll bars front and rear.

Engine

Koenigsegg aluminum 5,0L V8, 4 valves per cylinder, double overhead camshafts with flexfuel capability.
 Compression: 9.0:1
 Bore: 91.7 mm Stroke: 95.25 mm
 Sequential, multipoint fuel injection.
 Twin turbo superchargers

1.4 bar boost pressure.
 Dry sump lubrication.
 Carbon fibre intake manifold with optimised intake tracts.
 Tig-welded ceramic coated inconel exhaust system manifold with merge collector.
 Weight: 197 kg

Transmission

Specially developed 7-speed dual clutch, 1 input shaft transmission with paddle-shift.
 Electronic differential.

Steering

Rack and pinion power assisted steering. 2.7 turns lock-to-lock.
 Turning circle: 11 metres. TRW electro-hydraulic power-assisted.

Brakes

Front brakes: Ventilated ceramic discs Ø 397 mm, 40 mm wide. 6-piston calipers. Power-assisted.
 Rear brakes: Ventilated ceramic discs Ø 380 mm, 34 mm wide. 4-piston callipers. Power-assisted.
 Traction Control.
 F1-style for optimal performance with 5 different handling modes.

Wheels

Koenigsegg Aicore™ carbon wheels with centre locking
 Front: 19" x 9.5"
 Rear: 20" x 12.5"

Tyres

Dedicated Michelin Supersport
 Unidirectional with asymmetric thread pattern
 Front: 265/35 – 19" (Y)
 Rear: 345/30 – 20" (Y)
 Speed rating: 420+ km/h

Body

Two-door, two seater with removable hardtop stowable under the front hood lid. Body made from pre-impregnated carbonfibre/kevlar and lightweight sandwich reinforcements. Carbon vents over wheels.

Electrical System

Solid state digital semiconductors - no fuses or relays.
 Can bus operated and fully programmable functionality.

Equipment

Dual airbags, detachable storable hardtop with glass roof, power windows, adaptive rear wing, adjustable pedals and steering column, Agera stitching, adjustable seats in rake and length, carbon ceramic brakes with Sport ABS, EPS, hydraulic lifting system, power steering, power brakes, extra 4 point seatbelts for track use. Satnav, Intelligent LifePo4 battery, MP3 player, USB connection, climate control, digital warning and info system, G sensor, alarm, tyre monitoring system, silver key, leather carpets, roof storage bag, car cover, Inconel exhaust system, front winglets, rear view camera, Aicore™ wheels, side winglet, aero exhaust.

Extra Equipment

Fitted luggage, special leather and colour requests, full visible carbon body, heated seats, ski box roof, skis, winter wheel package.

3 Year Warranty.

All information correct at time of printing, and subject to change.

Agera R





"The Michelin Pilot Super Sports find traction and the car explodes down the road without the slightest correction on my part" Motortrend

KOENIGSEGG LIFESTYLE

Koenigsegg lifestyle is dedicated to bringing the core of the Koenigsegg brand in to products used in everyday life. We offer only very exclusive products, ranging from jewelry to clothing and accessories. Our limited edition products offer an exclusiveness found nowhere else. The Koenigsegg brand ensures us of that. Visit our brand new web shop and become a part of the Koenigsegg family today.



Find Koenigsegg merchandise at www.koenigsegg.com



Koenigsegg